

Compilers

CS414-2010-FR

Final Review

David Galles

Department of Computer Science
University of San Francisco

FR-0: Deterministic Finite Automata

- Set of states
- Initial State
- Final State(s)
- Transitions

DFA for else, end, identifiers

Combine DFA

FR-1: DFAs and Lexical Analyzers

- Given a DFA, it is easy to create C code to implement it
- DFAs are easier to understand than C code
 - Visual – almost like structure charts
- ... However, creating a DFA for a complete lexical analyzer is still complex

FR-2: Automatic Creation of DFAs

We'd like a tool:

- Describe the tokens in the language
- Automatically create DFA for tokens
- Then, automatically create C code that implements the DFA

We need a method for describing tokens

FR-3: Formal Languages

- **Alphabet Σ** : Set of all possible symbols (characters) in the input file
 - Think of Σ as the set of symbols on the keyboard
- **String w** : Sequence of symbols from an alphabet
- **String length $|w|$** : Number of characters in a string: $|\text{car}| = 3$, $|\text{abba}| = 4$
 - **Empty String ϵ** : String of length 0: $|\epsilon| = 0$
- **Formal Language**: Set of strings over an alphabet

Formal Language \neq Programming language – Formal Language is only a set of strings.

FR-4: Formal Languages

Example formal languages:

- Integers $\{0, 23, 44, \dots\}$
- Floating Point Numbers $\{3.4, 5.97, \dots\}$
- Identifiers $\{\text{foo}, \text{bar}, \dots\}$

FR-5: Language Concatenation

- Language Concatenation Given two formal languages L_1 and L_2 , the concatenation of L_1 and L_2 , $L_1L_2 = \{xy \mid x \in L_1, y \in L_2\}$

For example:

$\{\text{fire, truck, car}\} \{\text{car, dog}\} =$

$\{\text{firecar, firedog, truckcar, truckdog, carcar, cardog}\}$

FR-6: Kleene Closure

Given a formal language L :

$$L^0 = \{\epsilon\}$$

$$L^1 = L$$

$$L^2 = LL$$

$$L^3 = LLL$$

$$L^4 = LLLL$$

$$L^* = L^0 \cup L^1 \cup L^2 \cup \dots \cup L^n \cup \dots$$

FR-7: Regular Expressions

Regular expressions are used to describe formal languages over an alphabet Σ :

Regular Expression	Language
ϵ	$L[\epsilon] = \{\epsilon\}$
$a \in \Sigma$	$L[a] = \{a\}$
(MR)	$L[MR] = L[M]L[R]$
$(M R)$	$L[(M R)] = L[M] \cup L[R]$
(M^*)	$L[(M^*)] = L[M]^*$

FR-8: r.e. Precedence

From highest to Lowest:

Kleene Closure *

Concatenation

Alternation |

$$ab^*c|e = (a(b^*)c) | e$$

FR-9: Regular Expression Examples

$(a b)^*$	all strings over $\{a,b\}$
$(0 1)^*$	binary integers (with leading zeroes)
$a(a b)^*a$	all strings over $\{a,b\}$ that begin and end with a
$(a b)^*aa(a b)^*$	all strings over $\{a,b\}$ that contain aa
$b^*(abb^*)^*(a \epsilon)$	all strings over $\{a,b\}$ that do not contain aa

FR-10: r.e. Shorthand

$["a", "b", "c", "d"] = (a|b|c|d)$
 $["b"- "g"] = ["b", "e", "f", "g"] = (b|e|f|g)$
 $["b"- "g", "M"- "O"] = ["b", "e", "f", "g", "M", "N", "O"] = (b|e|f|g|M|N|O)$
 $M? = (M | \epsilon)$
 $M+ = MM^*$
 $"vc" = \text{The string } vc \text{ exactly}$

FR-11: r.e. Shorthand Examples

Regular Expression	Language
if	{if}
["a"-"z"]["0"-"9","a"-"z"]*	Set of legal identifiers
["0"-"9"]+	Set of integers (with leading zeros)
(["0"-"9"]+."["0"-"9"]*)	Set of real numbers
(["0"-"9"]*."["0"-"9"]+)	

FR-12: Parsing

- Once we have broken an input file into a sequence of tokens, the next step is to determine if that sequence of tokens forms a syntactically correct program – parsing
- We will use a tool to create a parser – just like we used lex to create a parser
- We need a way to describe syntactically correct programs
 - Context-Free Grammars

FR-13: Context-Free Grammars

- Set of Terminals (tokens)
- Set of Non-Terminals
- Set of Rules, each of the form:
 $\langle \text{Non-Terminal} \rangle \rightarrow \langle \text{Terminals \& Non-Terminals} \rangle$
- Special Non-Terminal – Initial Symbol

FR-14: Generating Strings with CFGs

- Start with the initial symbol
- Repeat:
 - Pick any non-terminal in the string
 - Replace that non-terminal with the right-hand side of some rule that has that non-terminal as a left-hand side

Until all elements in the string are terminals

FR-15: CFG Example

$$E \rightarrow E + E$$

$$E \rightarrow E - E$$

$$E \rightarrow E * E$$

$$E \rightarrow E / E$$

$$E \rightarrow \text{num}$$

FR-16: Parse Trees

A Parse Tree is a graphical representation of a derivation

$$E \Rightarrow E + E \Rightarrow E * E + E$$

$$\Rightarrow \text{num} * E + E \Rightarrow \text{num} * \text{num} + E$$

$$\Rightarrow \text{num} * \text{num} + \text{num}$$

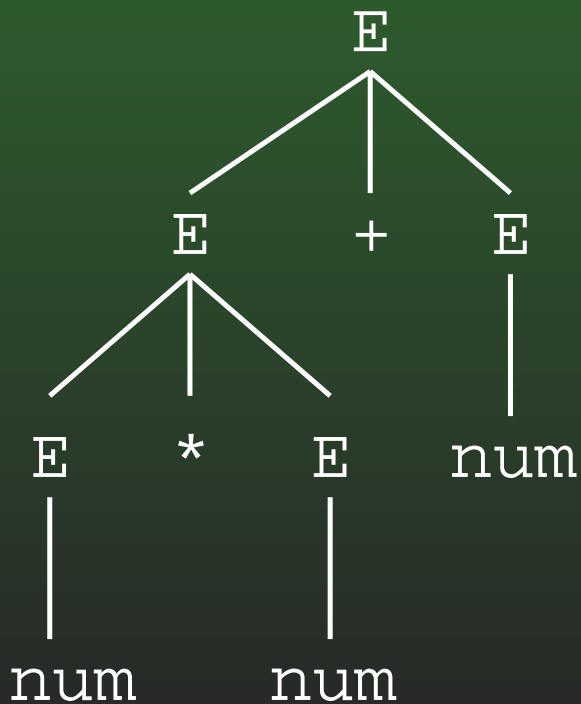

FR-17: Ambiguous Grammars

- A Grammar is *ambiguous* if there is at least one string with more than one parse tree
- The expression grammar we've seen so far is ambiguous

$$E \rightarrow E + E$$

$$E \rightarrow E - E$$

$$E \rightarrow E * E$$

$$E \rightarrow E / E$$

$$E \rightarrow \text{num}$$

FR-18: Expression Grammar

$$E \rightarrow E + T$$

$$E \rightarrow E - T$$

$$E \rightarrow T$$

$$T \rightarrow T * F$$

$$T \rightarrow T / F$$

$$T \rightarrow F$$

$$F \rightarrow \text{num}$$

$$F \rightarrow (E)$$

FR-19: CFG for Statements

- Expressions: id, num
- Function calls: id(<input params>)
 - <input params> are expressions separated by commas
- Block Statements { < list of statements > }
- While statements (C syntax)

All statements are terminated by a semi-colon ;

FR-20: CFG for Statements

$S \rightarrow \text{id}(P);$

$S \rightarrow \{L\}$

$S \rightarrow \text{while } (E) S$

$E \rightarrow \text{id} \mid \text{num}$

$P \rightarrow \epsilon$

$P \rightarrow EP'$

$P' \rightarrow \epsilon$

$P' \rightarrow , EP'$

$L \rightarrow \epsilon$

$L \rightarrow SL$

FR-21: LL(1) Parsers

These recursive descent parsers are also known as LL(1) parsers, for Left-to-right, Leftmost derivation, with 1 symbol lookahead

- The input file is read from left to right (starting with the first symbol in the input stream, and proceeding to the last symbol).
- The parser ensures that a string can be derived by the grammar by building a leftmost derivation.
- Which rule to apply at each step is decided upon after looking at just 1 symbol.

FR-22: Building LL(1) Parsers

$$S' \rightarrow S\$$$

$$S \rightarrow AB$$

$$S \rightarrow Ch$$

$$A \rightarrow ef$$

$$A \rightarrow \epsilon$$

$$B \rightarrow hg$$

$$C \rightarrow DD$$

$$C \rightarrow fi$$

$$D \rightarrow g$$

ParseS use rule $S \rightarrow AB$ on e, h
 use the rule $S \rightarrow Ch$ on f, g

FR-23: First sets

$\text{First}(S)$ is the set of all terminals that can start strings derived from S (plus ϵ , if S can produce ϵ)

$$S' \rightarrow S\$$$

$$\text{First}(S') =$$

$$S \rightarrow AB$$

$$\text{First}(S) =$$

$$S \rightarrow Ch$$

$$\text{First}(A) =$$

$$A \rightarrow ef$$

$$\text{First}(B) =$$

$$A \rightarrow \epsilon$$

$$\text{First}(C) =$$

$$B \rightarrow hg$$

$$\text{First}(D) =$$

$$C \rightarrow DD$$

$$C \rightarrow fi$$

$$D \rightarrow g$$

FR-24: First sets

$\text{First}(S)$ is the set of all terminals that can start strings derived from S (plus ϵ , if S can produce ϵ)

$$S' \rightarrow S\$$$

$$\text{First}(S') = \{e, f, g, h\}$$

$$S \rightarrow AB$$

$$\text{First}(S) = \{e, f, g, h\}$$

$$S \rightarrow Ch$$

$$\text{First}(A) = \{e, \epsilon\}$$

$$A \rightarrow ef$$

$$\text{First}(B) = \{h\}$$

$$A \rightarrow \epsilon$$

$$\text{First}(C) = \{f, g\}$$

$$B \rightarrow hg$$

$$\text{First}(D) = \{g\}$$

$$C \rightarrow DD$$

$$C \rightarrow fi$$

$$D \rightarrow g$$

FR-25: Calculating First sets

- For each non-terminal S , set $\text{First}(S) = \{\}$
- For each rule of the form $S \rightarrow \gamma$, add $\text{First}(\gamma)$ to $\text{First}(S)$
- Repeat until no changes are made

FR-26: Follow Sets

$\text{Follow}(S)$ is the set of all terminals that can follow S in a (partial) derivation.

$$S' \rightarrow S\$$$

$$S \rightarrow AB$$

$$S \rightarrow Ch$$

$$A \rightarrow ef$$

$$A \rightarrow \epsilon$$

$$B \rightarrow hg$$

$$C \rightarrow DD$$

$$C \rightarrow fi$$

$$D \rightarrow g$$

$$\text{Follow}(S') =$$

$$\text{Follow}(S) =$$

$$\text{Follow}(A) =$$

$$\text{Follow}(B) =$$

$$\text{Follow}(C) =$$

$$\text{Follow}(D) =$$

FR-27: Follow Sets

$\text{Follow}(S)$ is the set of all terminals that can follow S in a (partial) derivation.

$$S' \rightarrow S\$$$

$$\text{Follow}(S') = \{ \$ \}$$

$$S \rightarrow AB$$

$$\text{Follow}(S) = \{ \$ \}$$

$$S \rightarrow Ch$$

$$\text{Follow}(A) = \{ h \}$$

$$A \rightarrow ef$$

$$\text{Follow}(B) = \{ \$ \}$$

$$A \rightarrow \epsilon$$

$$\text{Follow}(C) = \{ h \}$$

$$B \rightarrow hg$$

$$\text{Follow}(D) = \{ h, g \}$$

$$C \rightarrow DD$$

$$C \rightarrow fi$$

$$D \rightarrow g$$

FR-28: Calculating Follow sets

- For each non-terminal S , set $\text{Follow}(S) = \{\}$
- For each rule of the form $S \rightarrow \gamma$
 - For each non-terminal S_1 in γ , where γ is of the form $\alpha S_1 \beta$
 - If $\text{First}(\beta)$ does not contain ϵ , add all elements of $\text{First}(\beta)$ to $\text{Follow}(S_1)$.
 - If $\text{First}(\beta)$ does contain ϵ , add all elements of $\text{First}(\beta)$ *except* ϵ to $\text{Follow}(S_1)$, and add all elements of $\text{Follow}(S)$ to $\text{Follow}(S_1)$.
- If any changes were made, repeat.

FR-29: Parse Tables

- Each row in a parse table is labeled with a non-terminal
- Each column in a parse table is labeled with a terminal
- Each element in a parse table is either empty, or contains a grammar rule
 - Rule $S \rightarrow \gamma$ goes in row S , in all columns of $\text{First}(\gamma)$.
 - If $\text{First}(\gamma)$ contains ϵ , then the rule $S \rightarrow \gamma$ goes in row S , in all columns of $\text{Follow}(S)$.

FR-30: LL(1) Example

$$E' \rightarrow E\$$$

$$E \rightarrow *E$$

$$E \rightarrow R$$

$$R \rightarrow ST$$

$$T \rightarrow .ST$$

$$T \rightarrow \epsilon$$

$$S \rightarrow \text{var}C$$

$$C \rightarrow [\text{num}] C$$

$$C \rightarrow \epsilon$$

FR-31: LL(1) Example

Non-Terminal	First	Follow
E'	$*, \text{var}$	
E	$*, \text{var}$	$\$$
R	var	$\$$
T	$., \epsilon$	$\$$
S	var	$., \$$
C	$[, \epsilon$	$., \$$

FR-32: LL(1) Example

	*	.	var	[num]	\$
E'	$E' \rightarrow E\$$		$E' \rightarrow E\$$				
E	$E \rightarrow *E$		$E \rightarrow R$				
R			$R \rightarrow ST$				
T		$T \rightarrow .ST$					$T \rightarrow \epsilon$
S			$S \rightarrow \text{var } C$				
C		$C \rightarrow \epsilon$		$C \rightarrow [\text{num}] C$			$C \rightarrow \epsilon$

FR-33: Parsing

- LL(1) – Left-to-right, Leftmost derivation, 1-symbol lookahead parsers
 - Need to guess which rule to apply after looking at only the first element in the rule
- LR parsers – Left-to-right, Rightmost derivation parsers
 - Look at the entire right-hand side of the rule before deciding which rule to apply

FR-34: LR Parsing

- Maintain a stack
- Shift terminals from the input stream to the stack, until the top of the stack is the same as the right-hand side of a rule
- When the top of the stack is the same as the right-hand side of a rule *reduce* by that rule – replace the right-hand side of the rule on the stack with the left-hand side of the rule.
- Continue shifting elements and reducing by rules, until the input has been consumed and the stack contains only the initial symbol

FR-35: LR(0) Parsing

- Reads the input file Left-to-Right $\underline{L}R(0)$
- Creates a Rightmost derivation $L\underline{R}(0)$
- No Lookahead (0-symbol lookahead) $LR(\underline{0})$

LR(0) parsers are the simplest of the LR parsers

FR-36: LR(0) Items

- An LR(0) item consists of
 - A rule from the CFG
 - A “.” in the rule, which indicates where we currently are in the rule
- $S \rightarrow ab . c$
 - Trying to parse the rule $S \rightarrow abc$
 - Already seen “ab”, looking for a “c”

FR-37: LR(0) States & Transitions

(0) $S' \rightarrow S\$$

(1) $S \rightarrow AA$

(2) $S \rightarrow bc$

(3) $S \rightarrow baA$

(4) $A \rightarrow c$

FR-38: LR(0) States & Transitions

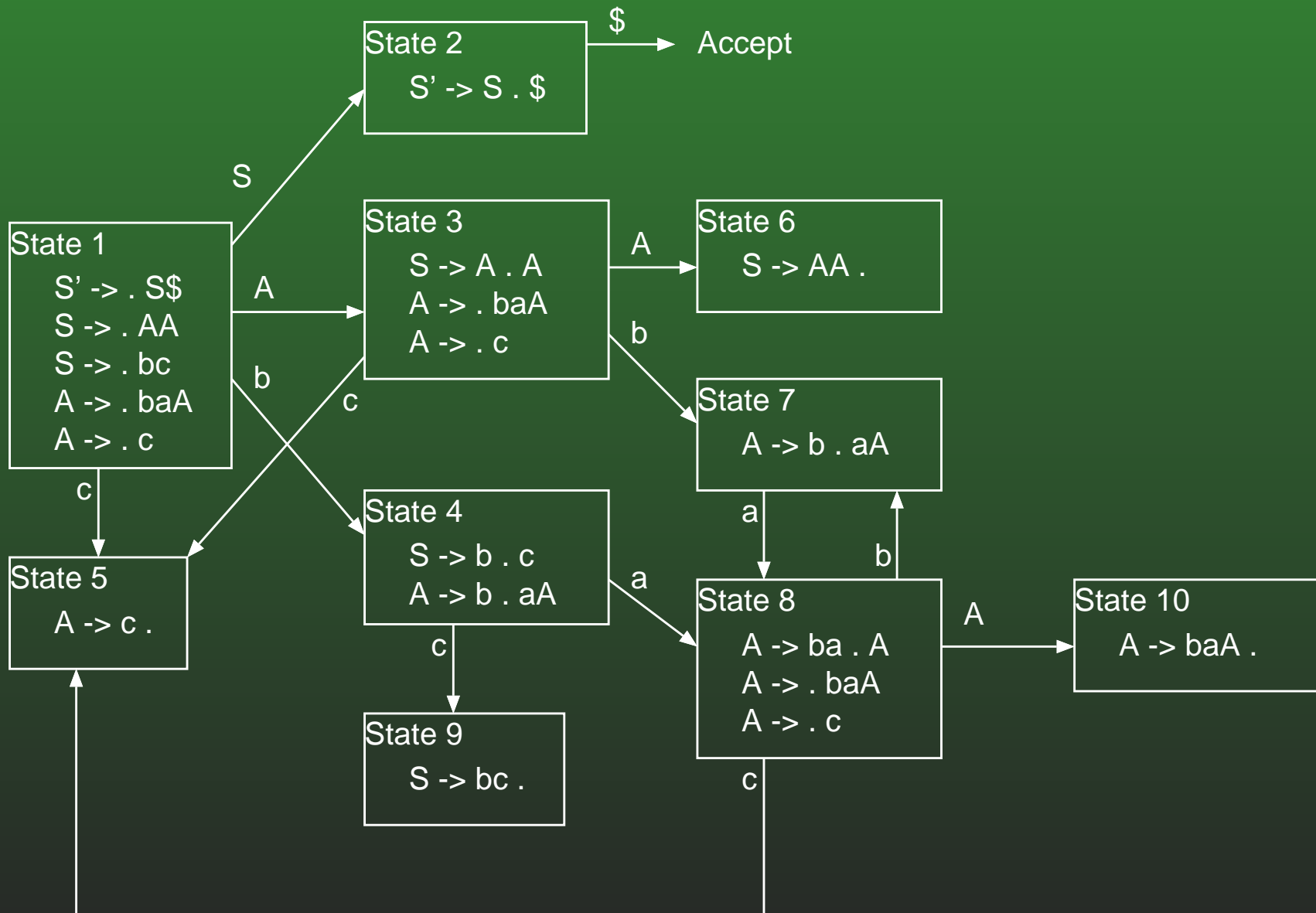

FR-39: LR(0) Parse Table

	a	b	c	\$	S	A
1		s4	s5		g2	
2				accept		
3		s7	s5			g6
4	s8		s9			
5	r(4)	r(4)	r(4)	r(4)		
6	r(1)	r(1)	r(1)	r(1)		
7	s8					
8		s7	s5			g10
9	r(2)	r(2)	r(2)	r(2)		
10	r(3)	r(3)	r(3)	r(3)		

FR-40: Another LR(0) Example

$$(0) S' \rightarrow S\$$$

$$(1) S \rightarrow CS$$

$$(2) S \rightarrow \epsilon$$

$$(3) C \rightarrow ab$$

$$(4) C \rightarrow a$$

FR-41: LR(0) States & Transitions

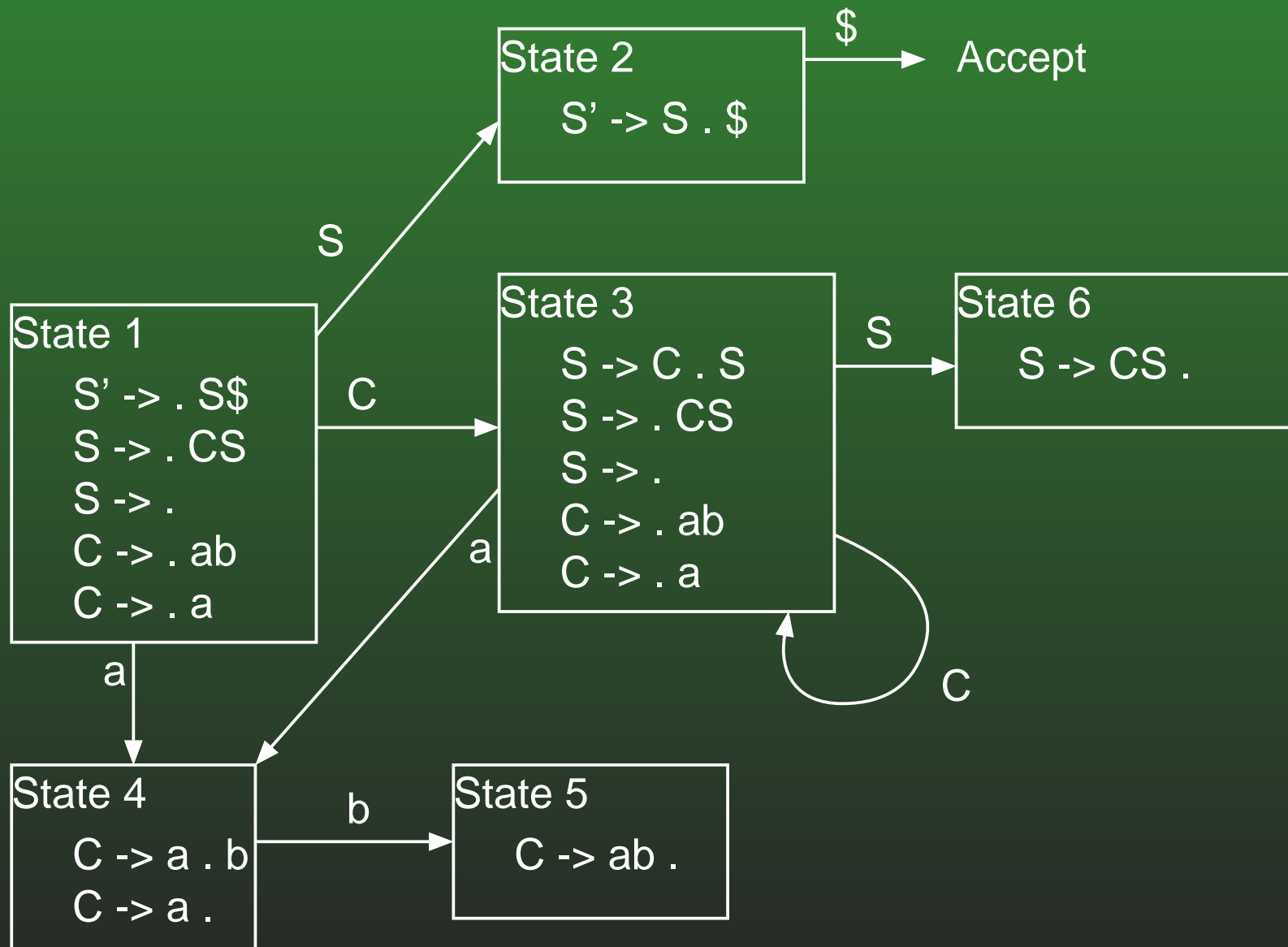

FR-42: LR(0) Parse Table

	a	b	\$	S'	S	C
1	s4,r(2)	r(2)	r(2)		g2	g3
2			accept			
3	s4,r(2)	r(2)	r(2)		g6	g3
4	r(4)	s5,r(4)	r(4)			
5	r(3)	r(3)	r(3)			
6	r(1)	r(1)	r(1)			

FR-43: SLR(1)

- Add simple lookahead (the S in SLR(1) is for *simple*)
- In LR(0) parsers, if state k contains the item “ $S \rightarrow \gamma \cdot$ ” (where $S \rightarrow \gamma$ is rule (n))
 - Put $r(n)$ in state k , in all columns
- In SLR(0) parsers, if state k contains the item “ $S \rightarrow \gamma \cdot$ ” (where $S \rightarrow \gamma$ is rule (n))
 - Put $r(n)$ in state k , in all columns *in the follow set of S*

FR-44: SLR(1) Parse Table

	First	Follow
S'	a	
S	a	\$
C	a	a, \$

	a	b	\$	S'	S	C
1	s4		r(2)		g2	g3
2			accept			
3	s4		r(2)		g6	g3
4	r(4)	s5	r(4)			
5	r(3)		r(3)			
6			r(1)			

FR-45: LR(1) Items

- Like LR(0) items, contain a rule with a “.”
- Also contain lookahead information – the terminals that could follow this rule, *in the current derivation*
 - More sophisticated than SLR(1), which only look at what terminals could follow the LHS of the rule in *any* derivation

FR-46: LR(1) Example

$$(0) S' \rightarrow S\$$$

$$(1) S \rightarrow AB$$

$$(2) A \rightarrow aA$$

$$(3) A \rightarrow \epsilon$$

$$(4) B \rightarrow bB$$

$$(5) B \rightarrow \epsilon$$

FR-47: LR(1) Example

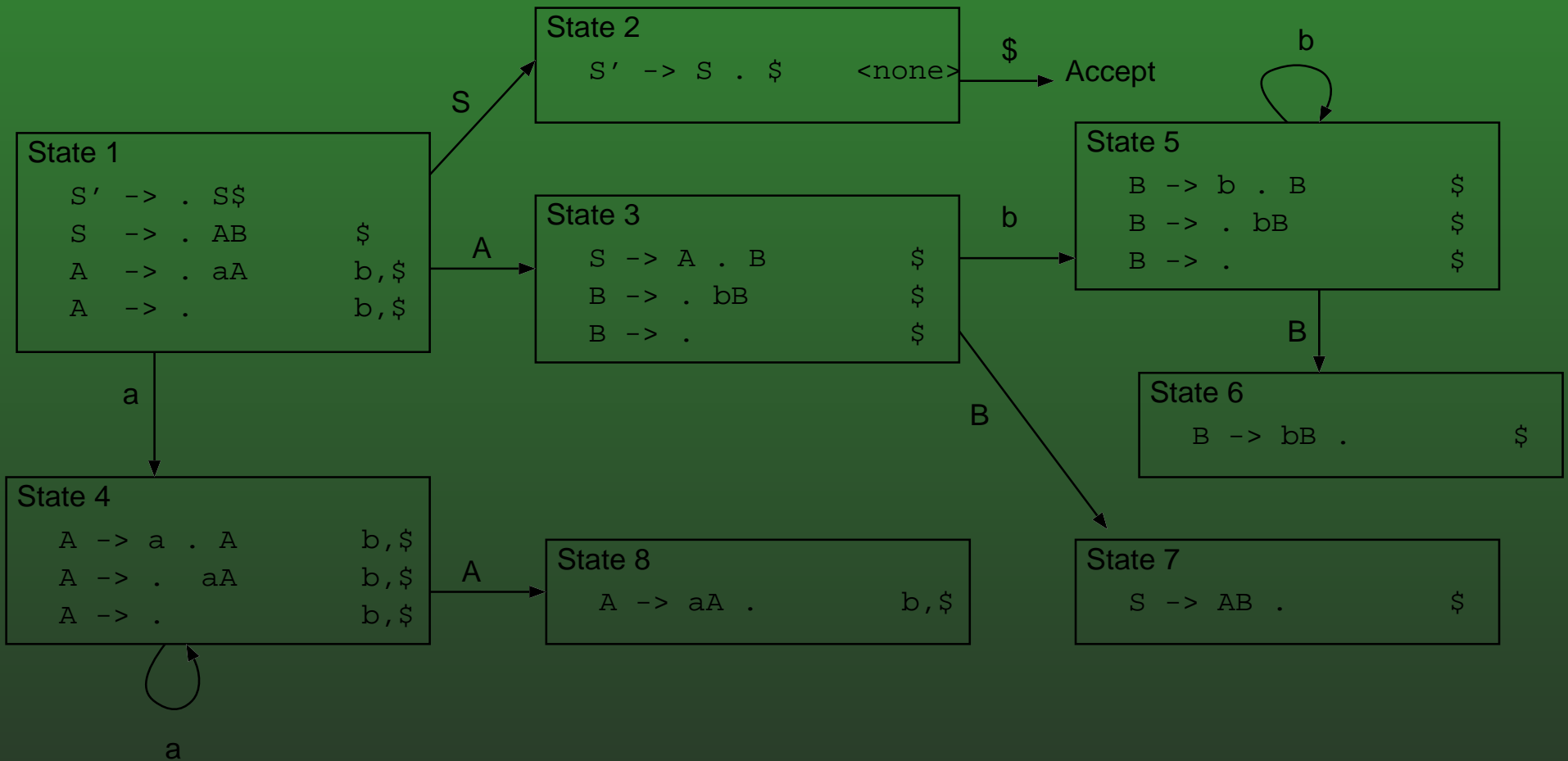

FR-48: LR(1) Example

	a	b	\$	S'	S	A	B
1	s4	r(3)	r(3)		g2	g3	
2			accept				
3		s5	r(5)				g7
4	s4	r(3)	r(3)			g8	
5		s5	r(5)				g6
6			r(4)				
7			r(1)				
8		r(2)	r(2)				

FR-49: Abstract Syntax Tree (AST)

- Parse trees tell us exactly how a string was parsed
- Parse trees contain more information than we need
 - We only need the basic shape of the tree, not where every non-terminal is
 - Non-terminals are necessary for parsing, not for meaning
- An Abstract Syntax Tree is a simplified version of a parse tree – basically a parse tree without non-terminals

FR-50: Parse Tree Example

$$E \rightarrow E + T$$

$$E \rightarrow T$$

$$T \rightarrow T * F$$

$$T \rightarrow F$$

$$F \rightarrow \text{num}$$

Parse tree for $3 + 4 * 5$

FR-51: Parse Tree Example

$$E \rightarrow E + T$$

$$E \rightarrow T$$

$$T \rightarrow T * F$$

$$T \rightarrow F$$

$$F \rightarrow \text{num}$$

Parse tree for $3 + 4 * 5$

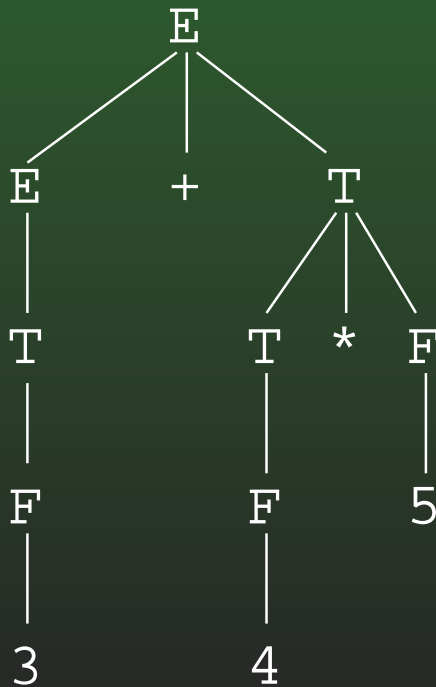

FR-52: Abstract Syntax Tree Example

$$E \rightarrow E + T$$

$$E \rightarrow T$$

$$T \rightarrow T * F$$

$$T \rightarrow F$$

$$F \rightarrow \text{num}$$

Abstract Syntax Tree for $3 + 4 * 5$

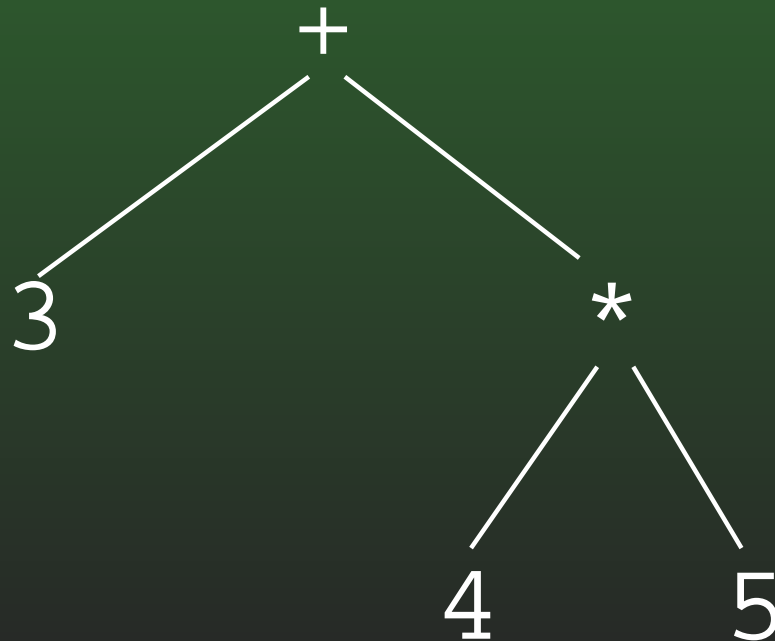

FR-53: AST – Expressions

- Simple expressions (such as integer literals) are a single node
- Binary expressions (+, *, /, etc.) are represented as a root (which stores the operation), and a left and right subtree
 - $5 + 6 * 7 + 8$ (on whiteboard)

FR-54: AST – Expressions

- What about parentheses? Do we need to store them?
 - Parenthesis information is store in the shape of the tree
 - No extra information is necessary

$3 * (4 + 5)$

FR-55: AST – Expressions

$3 * (4 + 5)$

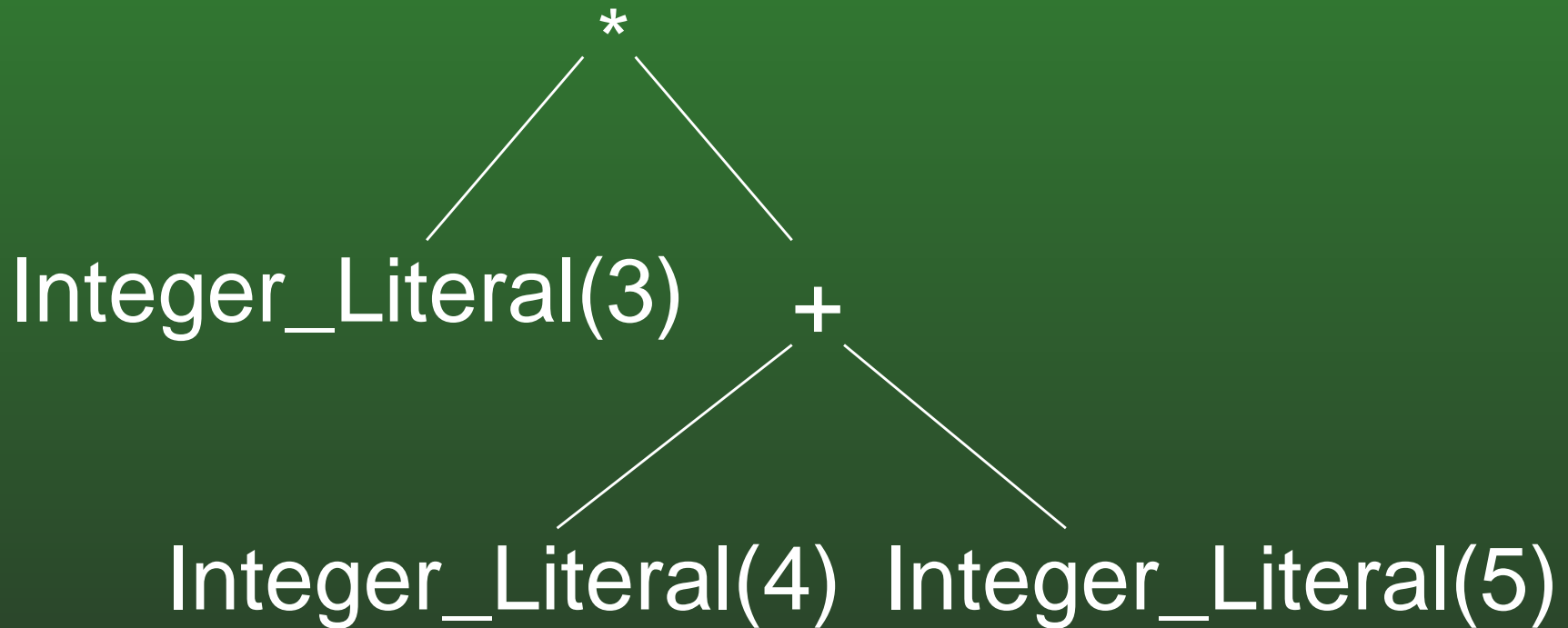

FR-56: AST – Variables

- Simple variables (which we will call *Base Variables*) can be described by a single identifier.
- Instance variable accesses ($x.y$) require the name of the base variable (x), and the name of the instance variable (y).
- Array accesses ($A[3]$) require the base variable (x) and the array index (3).
- Variable accesses need to be extensible
 - $x.y[3].z$

FR-57: AST – Variables

- Base Variables Root is “BaseVar”, single child (name of the variable)
- Class Instance Variables Root is “ClassVar”, left subtree is the “base” of the variable, right subtree is the instance variable name
- Array Variables Root is “ArrayVar”, left subtree is the “base” of the variable, right subtree is the index

FR-58: AST – Variables

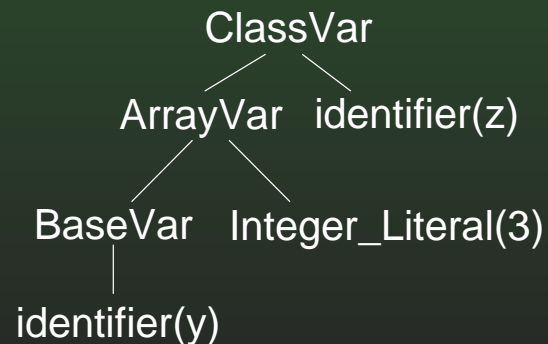
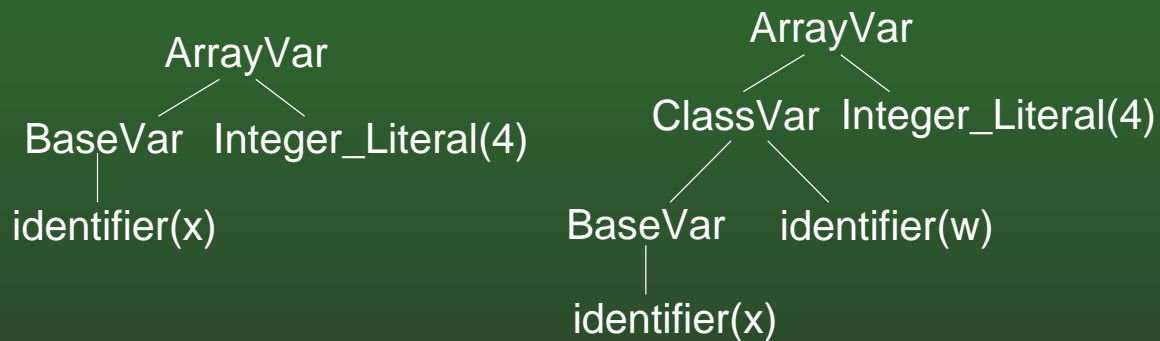

FR-59: AST – Instance Variables

```
class simpleClass {
    int a;
    int b;
}

class complexClass {
    int u;
    simpleClass v;
}

void main() {
    complexClass x;
    x = new complexClass();
    x.v = new simpleClass();

    x.v.a = 3;
}
```

FR-60: **AST – Instance Variables**

x.v.a

FR-61: AST – Instance Variables

x.v.a

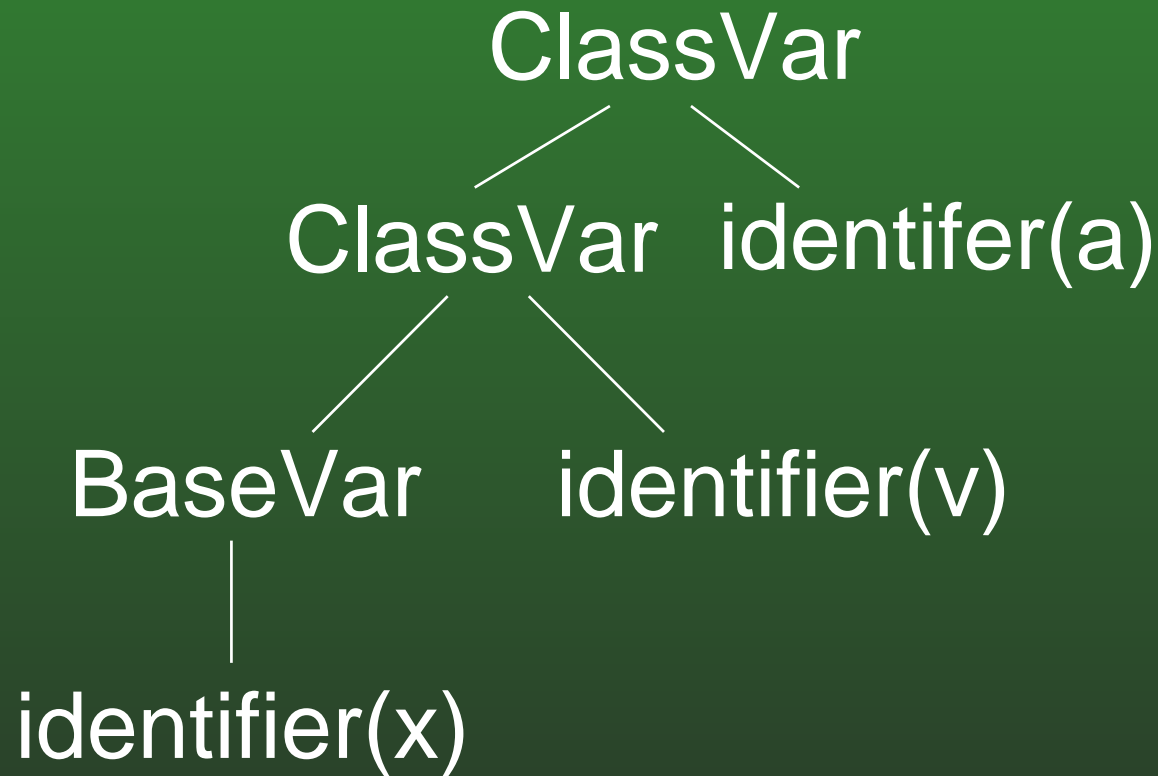

FR-62: **AST – Instance Variables**

W.X.Y.Z

FR-63: AST – Instance Variables

w.x.y.z

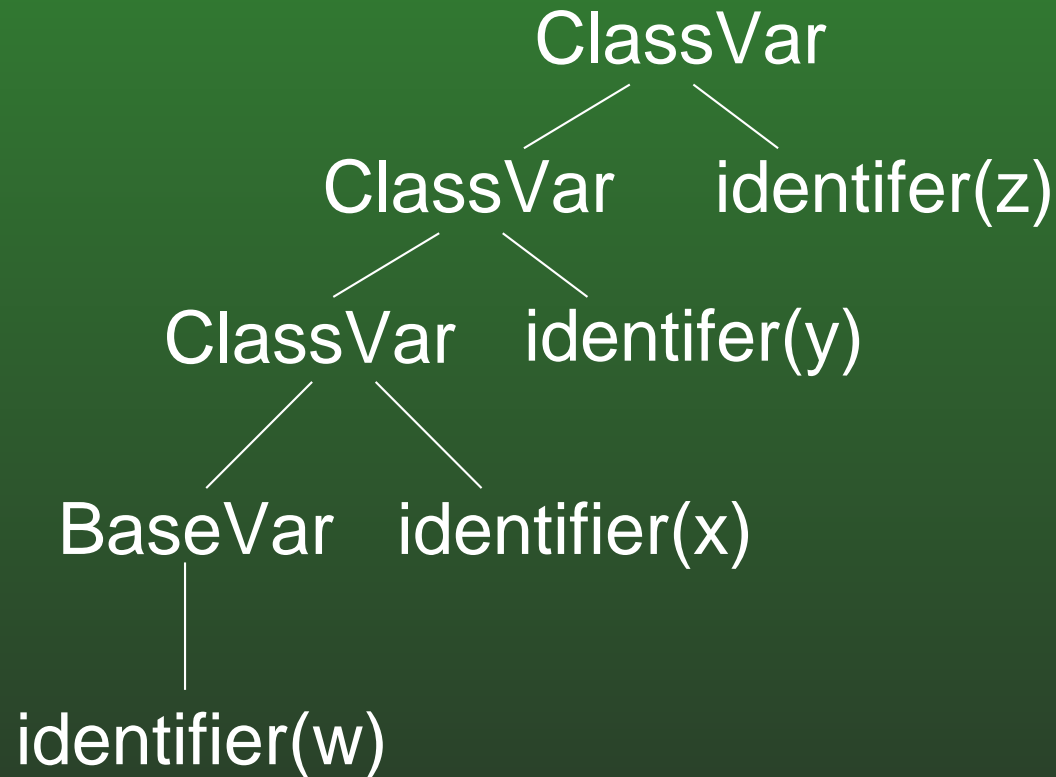

FR-64: **AST – Instance Variables**

v.w[x.y].z

FR-65: AST – Instance Variables

v.w[x.y].z

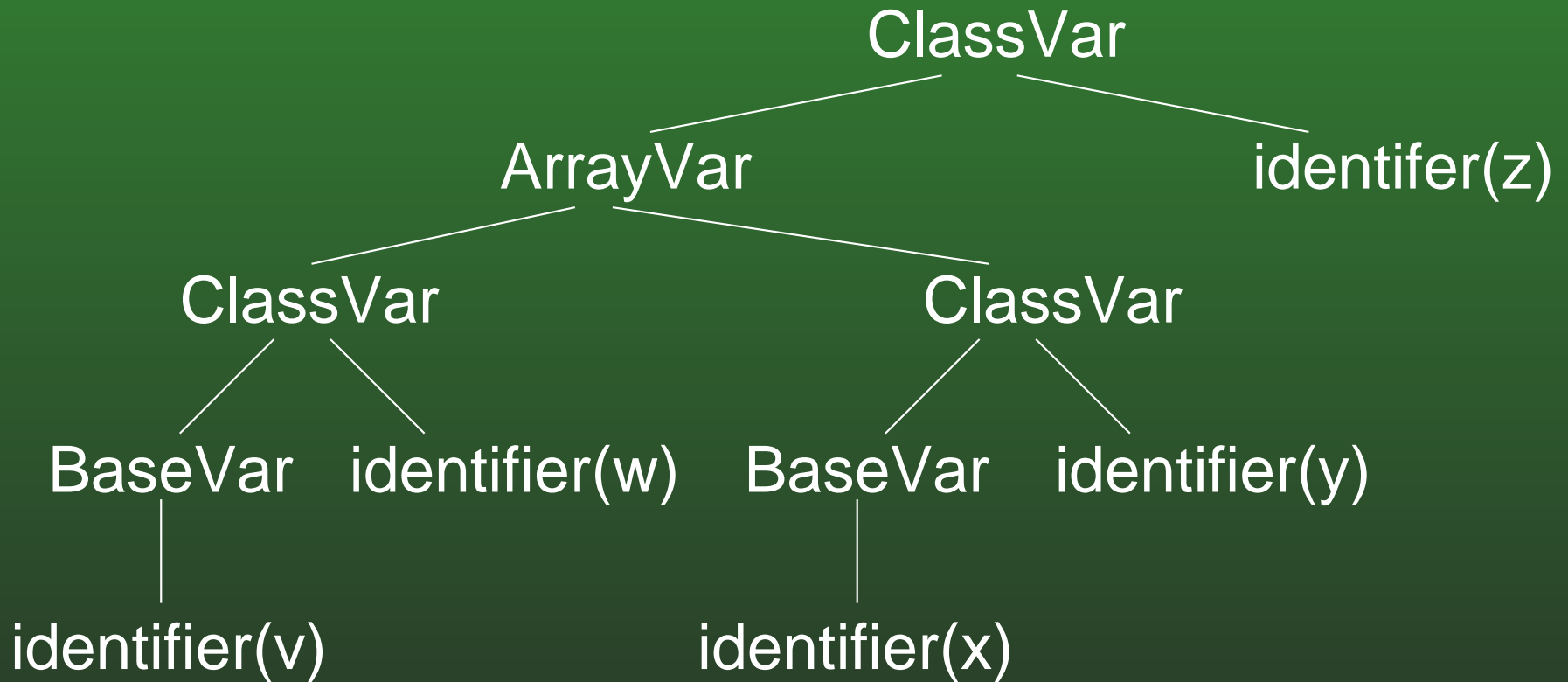

FR-66: AST – Statements

- Assignment Statement Root is “Assign”, children for left-hand side of assignment statement, and right-hand side of assignment statement

assign

```
graph TD; assign[assign] --- LHS[Variable tree for the Left-Hand Side of the assignment statement (destination)]; assign --- RHS[Variable tree for the Right-Hand Side of the assignment statement (value to assign)];
```

Variable tree for
the Left-Hand Side
of the assignment
statement (destination)

Variable tree for
the Right-Hand Side
of the assignment
statement (value to assign)

FR-67: AST – Statements

- If Statement Root is “If”, children for test, “then” clause, and “else” clause of the statement. The “else” tree may be empty, if the statement has no else.

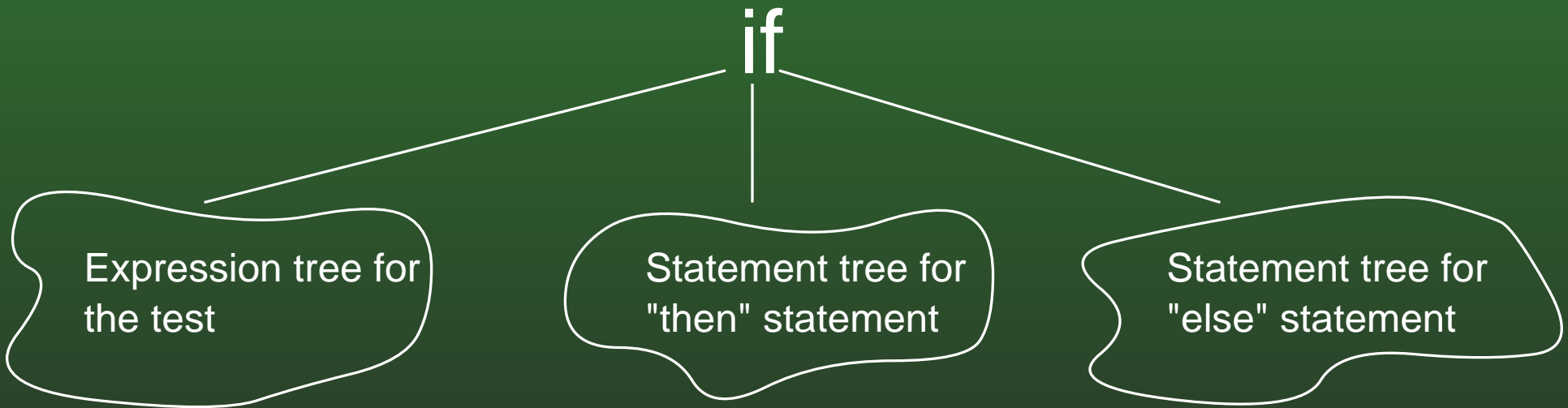

FR-68: AST – Statements

- Pascal-style for loops:

```
for i = 0 to 10 do ...
```

```
for j = 10 downto 3 do ...
```

- If we are designing a new AST node for Pascal-style for loops, what should it look like? How many children? What should they be?

FR-69: AST – Statements

- Pascal-style for loops:

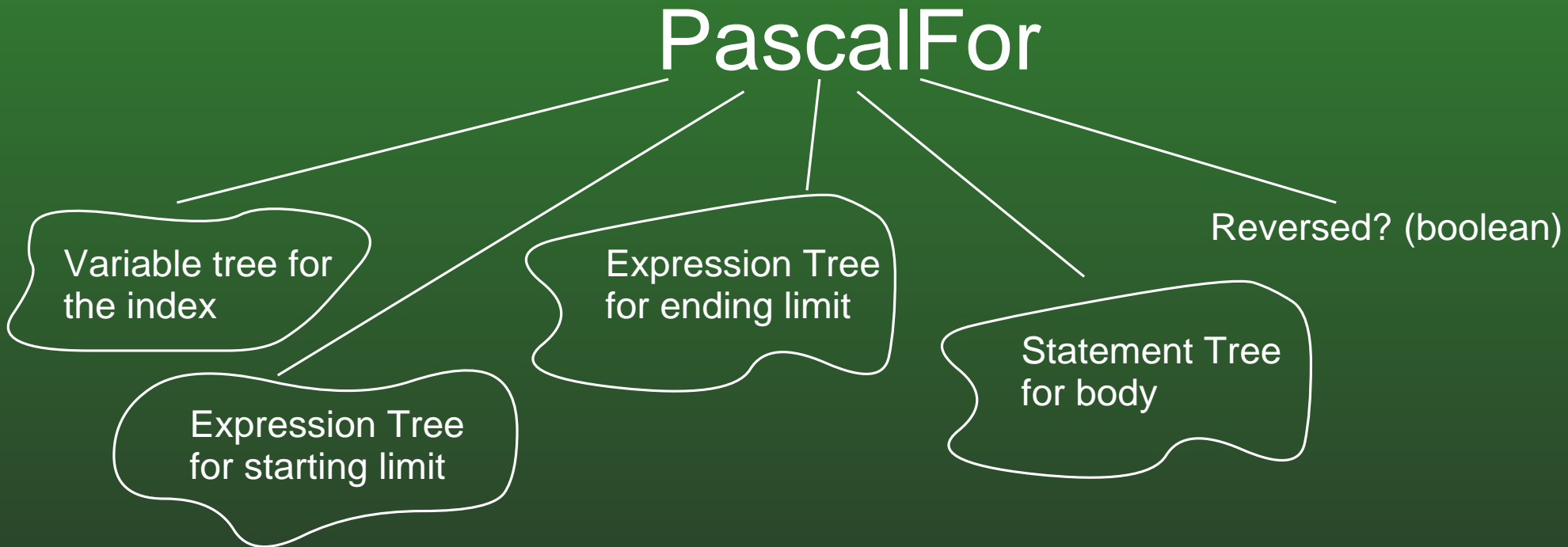

FR-70: AST – Statements

- Pascal-style for loops:

```
for i = 1 to 5 do x = x + i;
```

FR-71: AST – Statements

```
for i = 1 to 5 do x = x + i;
```

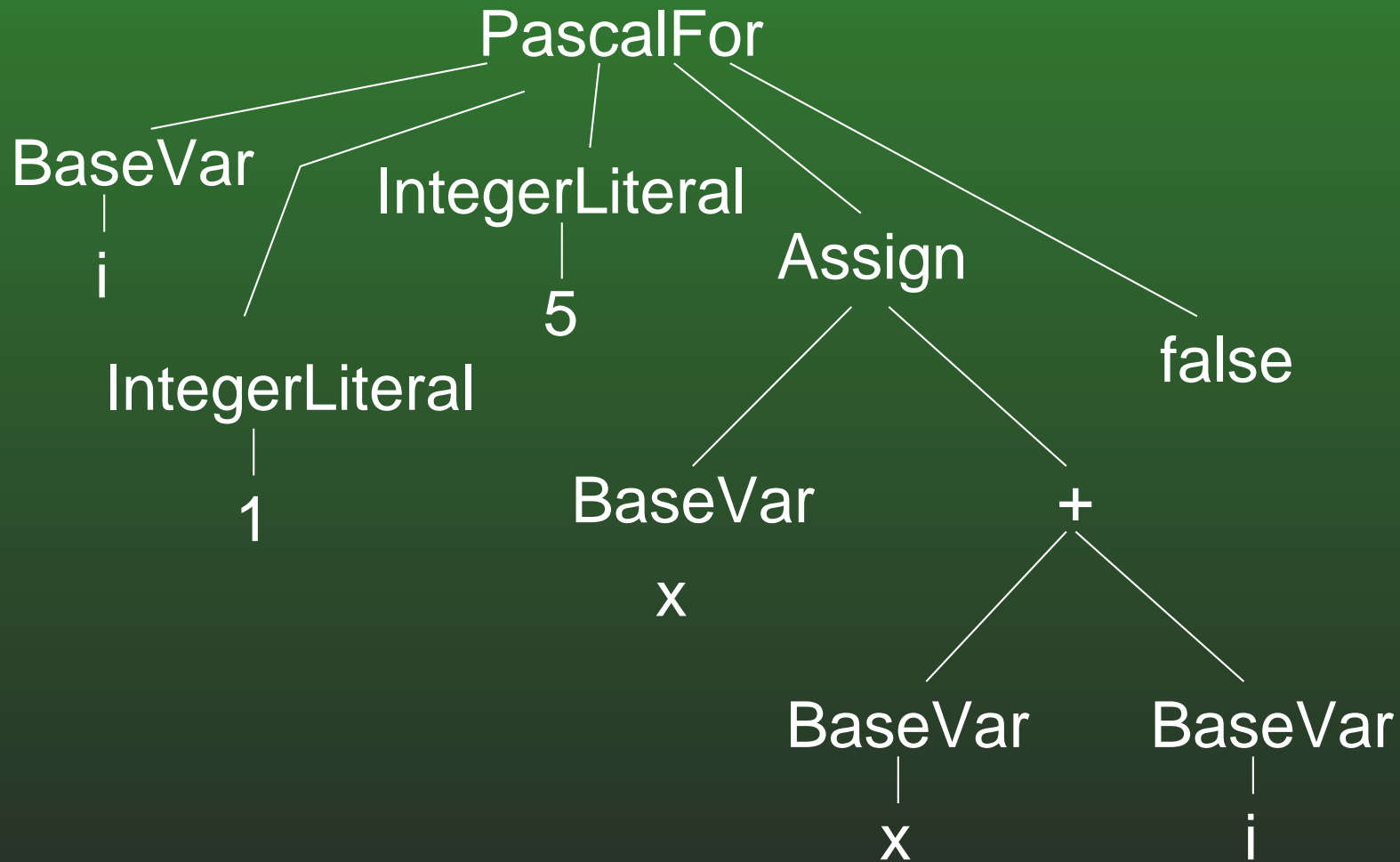

FR-72: Syntax / Semantic Errors

- A program has *syntax* errors if it cannot be generated from the Context Free Grammar which describes the language
- The following code has no *syntax* errors, though it has plenty of *semantic* errors:

```
void main() {  
    if (3 + x - true)  
        x.y.z[3] = foo(z)  
}
```

- Why don't we write a CFG for the language, so that all syntactically correct programs also contain no semantic errors?

FR-73: Syntax / Semantic Errors

- Why don't we write a CFG for the language, so that all syntactically correct programs also contain no semantic errors?
- In general, we can't!
 - In simpleJava, variables need to be declared before they are used
 - The following CFG:
 - $L = \{ww \mid w \in \{a, b\}^*\}$is *not* Context-Free – if we can't generate this string from a CFG, we certainly can't generate a simpleJava program where all variables are declared before they are used.

FR-74: Semantic Errors

- Semantic Errors can be classified into the following broad categories:
- **Definition Errors**
- Most strongly typed languages require variables, functions, and types to be defined before they are used with some exceptions –
 - Implicit variable declarations in Fortran
 - Implicit function definitions in C

FR-75: Semantic Errors

- Semantic Errors can be classified into the following broad categories:
- Structured Variable Errors
 - $x.y = A[3]$
 - x needs to be a class variable, which has an instance variable y
 - A needs to be an array variable
 - $x.y[z].w = 4$
 - x needs to be a class variable, which has an instance variable y , which is an array of class variables that have an instance variable w

FR-76: Semantic Errors

- Semantic Errors can be classified into the following broad categories:
 - **Function and Method Errors**
 - `foo(3, true, 8)`
 - foo must be a function which takes 3 parameters:
 - integer
 - boolean
 - integer

FR-77: Semantic Errors

- Semantic Errors can be classified into the following broad categories:
 - **Type Errors**
 - Build-in functions – /, *, ||, &&, etc. – need to be called with the correct types
 - In simpleJava, +, -, *, / all take integers
 - In simpleJava, || &&, ! take booleans
 - Standard Java has polymorphic functions & type coercion

FR-78: Semantic Errors

- Semantic Errors can be classified into the following broad categories:
 - **Type Errors**
 - Assignment statements must have compatible types
 - When are types compatible?

FR-79: Semantic Errors

- Semantic Errors can be classified into the following broad categories:
 - **Type Errors**
 - Assignment statements must have compatible types
 - In Pascal, only *Identical* types are compatible

FR-80: Semantic Errors

- Semantic Errors can be classified into the following broad categories:
 - **Type Errors**
 - Assignment statements must have compatible types
 - In C, types must have the same structure
 - Coerceable types also apply

```
struct {  
    int x;  
    char y;  
} var1;
```

```
struct {  
    int z;  
    char x;  
} var2;
```

FR-81: Semantic Errors

- Semantic Errors can be classified into the following broad categories:
 - **Type Errors**
 - Assignment statements must have compatible types
 - In Object oriented languages, can assign superclass value to a subclass variable

FR-82: Semantic Errors

- Semantic Errors can be classified into the following broad categories:
 - Access Violation Errors
 - Accessing private / protected methods / variables
 - Accessing local functions in block structured languages
 - Separate files (C)

FR-83: Environment

- Much of the work in semantic analysis is managing environments
- Environments store current definitions:
 - Names (and structures) of types
 - Names (and types) of variables
 - Names (and return types, and number and types of parameters) of functions
- As variables (functions, types, etc) are declared, they are added to the environment. When a variable (function, type, etc) is accessed, its definition in the environment is checked.

FR-84: Implementing Environments

- Environments are implemented with Symbol Tables
- Symbol Table ADT:
 - Begin a new scope.
 - Add a key / value pair to the symbol table
 - Look up a value given a key. If there are two elements in the table with the same key, return the most recently entered value.
 - End the current scope. Remove all key / value pairs added since the last begin scope command

FR-85: Implementing Symbol Tables

- Implement a Symbol Table as an open hash table
 - Maintain an array of lists, instead of just one
 - Store (key/value) pair in the front of $\text{list}[\text{hash}(\text{key})]$, where hash is a function that converts a key into an index
 - If:
 - The hash function distributes the keys evenly throughout the range of indices for the list
 - # number of lists = $\Theta(\# \text{ of key/value pairs})$
- Then inserting and finding take time $\Theta(1)$

FR-86: Implementing Symbol Tables

- What about `beginScope` and `endScope`?
- The key/value pairs are distributed across several lists – how do we know which key/value pairs to remove on an `endScope`?
 - If we knew exactly which variables were inserted since the last `beginScope` command, we could delete them from the hash table
 - If we always enter and remove key/value pairs from the beginning of the appropriate list, we will remove the correct items from the environment when duplicate keys occur.
 - How can we keep track of which keys have been added since the last `beginScope`?

FR-87: Implementing Symbol Tables

- How can we keep track of which keys have been added since the last beginScope?
- Maintain an auxiliary stack
 - When a key/value pair is added to the hash table, push the key on the top of the stack.
 - When a “Begin Scope” command is issued, push a special begin scope symbol on the stack.
 - When an “End scope” command is issued, pop keys off the stack, removing them from the hash table, until the begin scope symbol is popped

FR-88: Abstract Assembly Trees

- Once we have analyzed the AST, we can start to produce code
- We will *not* produce actual assembly directly – we will go through (yet another) internal representation – Abstract Assembly Trees
 - Translating from AST to assembly is difficult – much easier to translate from AST to AAT, and (relatively) easy to translate from AAT to assembly.
 - Optimizations will be easier to implement using AATs.
 - Writing a compiler for several different targets (i.e., x86, MIPS) is much easier when we go through AATs

FR-89: Implementing Variables

- In simpleJava, all local variables (and parameters to functions) are stored on the stack.
 - (Modern compilers use registers to store local variables wherever possible, and only resort to using the stack when absolutely necessary – we will simplify matters by always using the stack)
- Class variables and arrays are stored on the heap (but the *pointers* to the heap are stored on the stack)

FR-90: Activation Records

- Each function has a segment of the stack which stores the data necessary for the implementation of the function
 - Mostly the local variables of the function, but some other data (such as saved register values) as well.
- The segment of the stack that holds the data for a function is the “Activation Record” or “Stack Frame” of the function

FR-91: Stack Implementation

- Stack is implemented with two registers:
 - Frame Pointer (FP) points to the beginning of the current stack. frame
 - Stack Pointer (SP) points to the next free address on the stack.
- Stacks grow from large addresses to small addresses.

FR-92: Stack Frames

- The stack frame for a function `foo()` contains:
 - Local variables in `foo`
 - Saved registers & other system information
 - Parameters of functions *called by* `foo`

FR-93: Stack Frames

```
int foo() {  
    int a;  
    int b;  
  
    /* body of foo */  
}
```

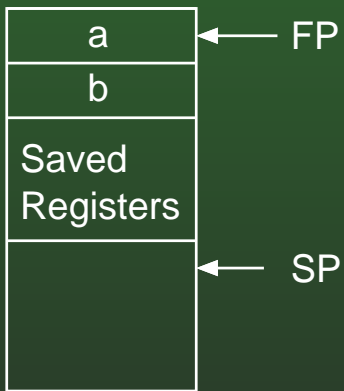

FR-94: Stack Frames

```
void foo(int a, int b);  
void bar(int c, int d);
```

```
void main() {  
    int u;  
    int v;  
  
    /* Label A */  
  
    bar(1,2);  
}  
  
int foo(int c, int d) {  
    int y;  
    int z;  
  
    /* Label B */  
}
```

```
void bar(int a, int b) {  
    int w;  
    int x;  
  
    foo(3,4);  
}
```

FR-95: Stack Frames

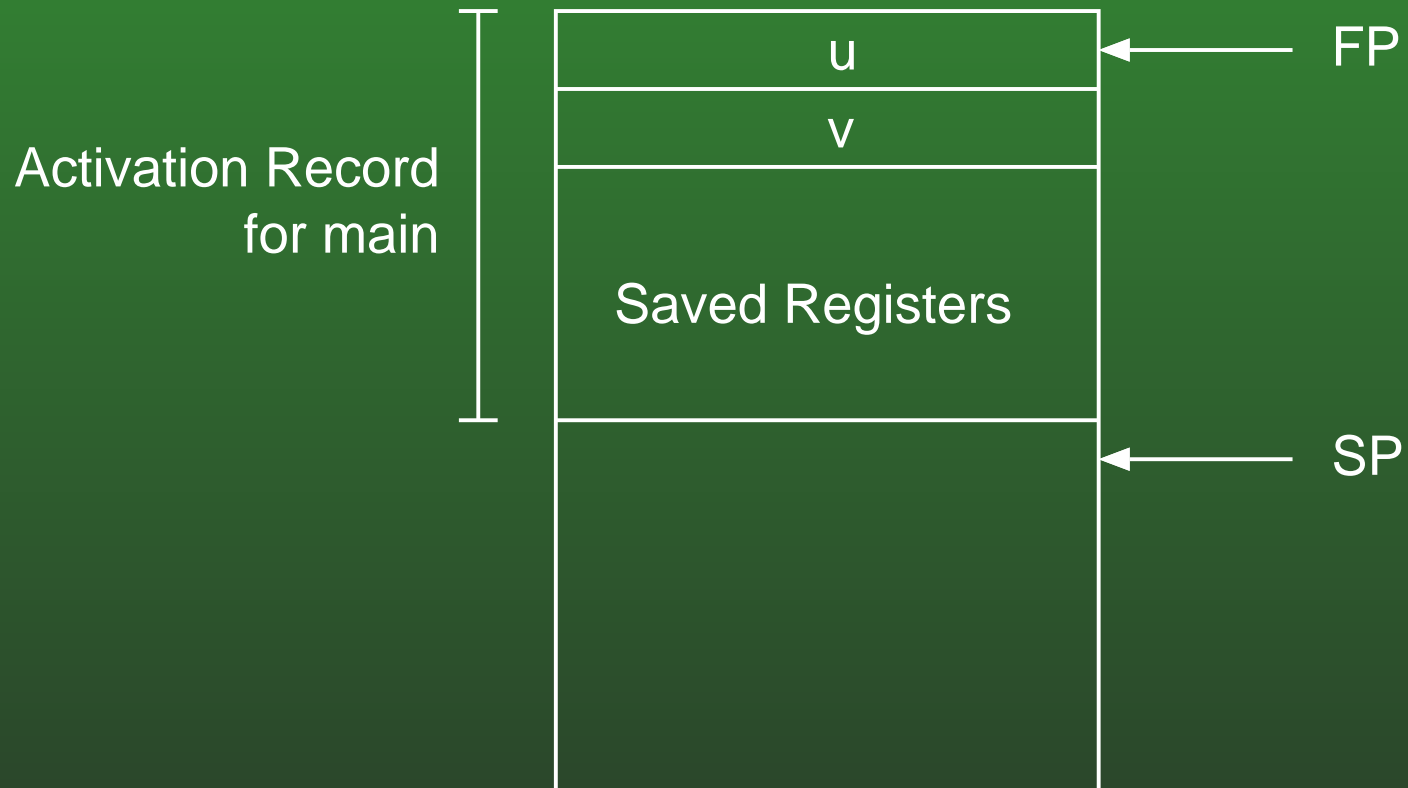

FR-96: Stack Frames

```
void foo(int a, int b);  
void bar(int c, int d);
```

```
void main() {  
    int u;  
    int v;  
  
    /* Label A */  
  
    bar(1,2);  
}  
  
int foo(int c, int d) {  
    int y;  
    int z;  
  
    /* Label B */  
}
```

```
void bar(int a, int b) {  
    int w;  
    int x;  
  
    foo(3,4);  
}
```

FR-97: Stack Frames

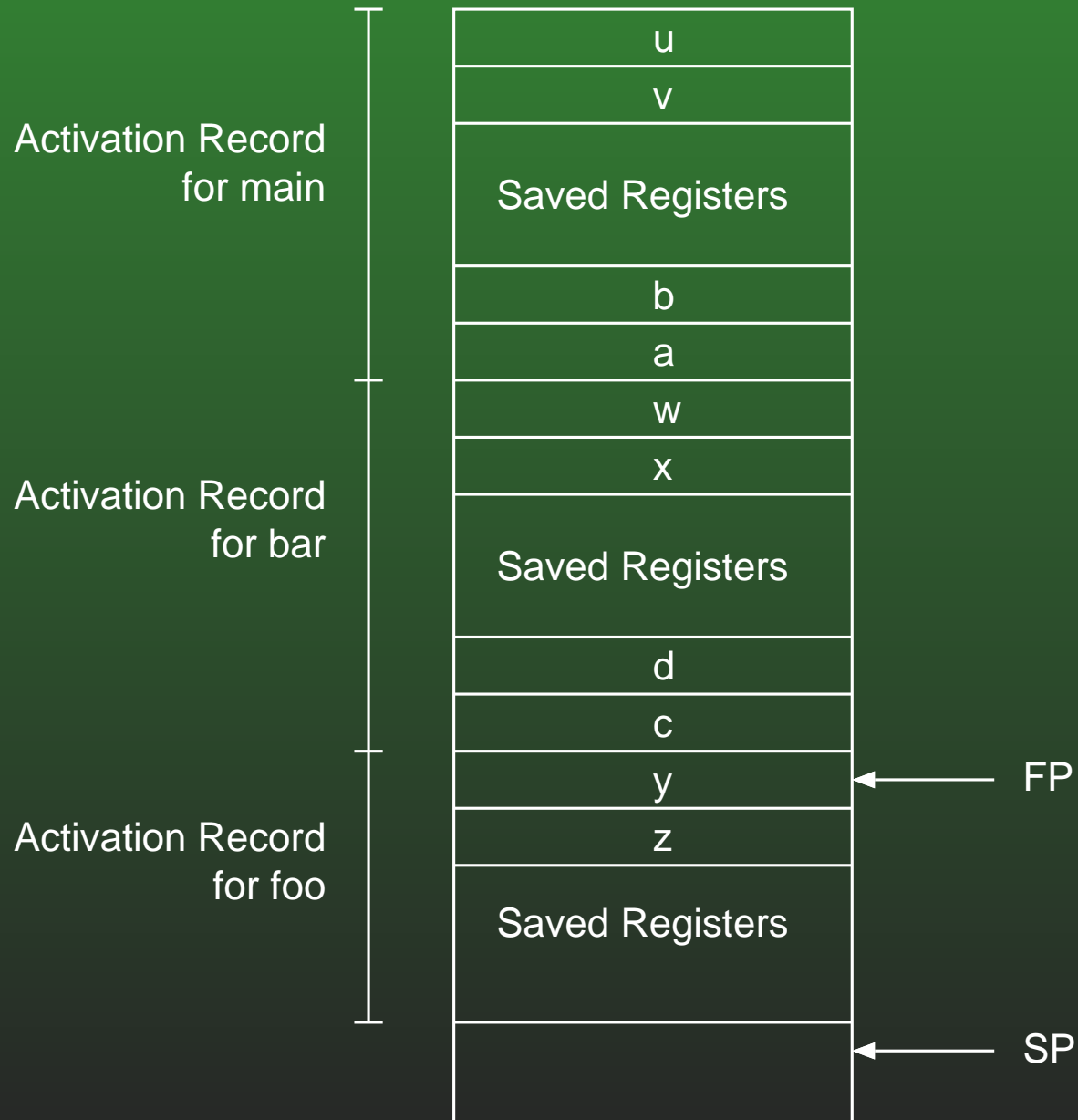

FR-98: Accessing Variables

- Local variables can be accessed from the frame pointer
 - Subtract the offset of the variable from the frame pointer
 - (remember – stacks grow down!)
- Input parameters can also be accessed from the frame pointer
- Add the offset of the parameter to the frame pointer

FR-99: Setting up stack frames

- Each function is responsible for setting up (and cleaning up) its own stack frame
- Parameters are in the activation record of the calling function
 - Calling function places parameters on the stack
 - Calling function cleans up parameters after the call (by incrementing the Stack Pointer)

FR-100: **Abstract Assembly**

- There are two kinds of Assembly Trees:
 - Expression Trees, which represent values
 - Statement Trees, which represent actions
- Just like Abstract Syntax Trees

FR-101: Expression Trees

- Constant Expressions
 - Stores the value of the constant.
 - Only integer constants
 - (booleans are represented as integers, just as in C)

FR-102: Expression Trees

- Memory Expression
 - Represents a memory dereference. Contains the memory location to examine.
 - Memory location 1006 is represented by the assembly tree:

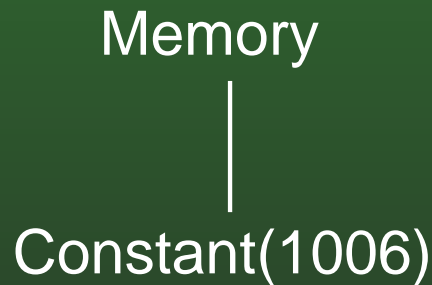

FR-103: Expression Trees

- Memory Expression
 - Represents a memory dereference. Contains the memory location to examine.
 - Local variable with an offset of 4 off the FP is

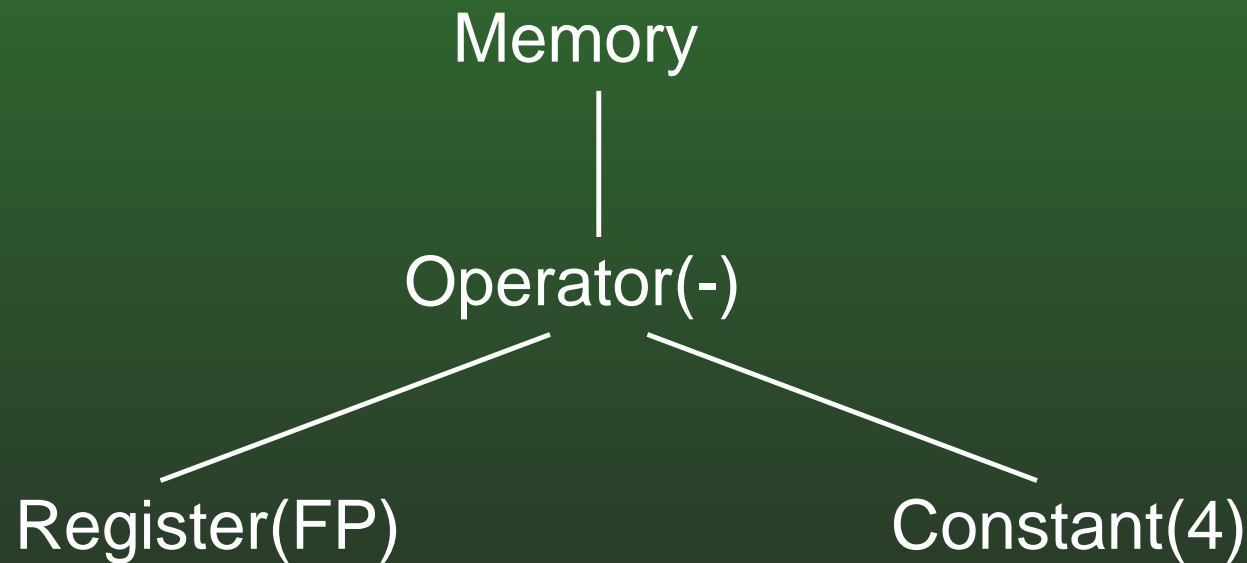

FR-104: Statement Trees

- Move Statements
 - Move statements are used to move data into either a memory location or a register
 - Left subtree of a move statement must be a register or memory expression
 - Right subtree of a move statement is any expression
 - To store the value 36 in the Frame Pointer:

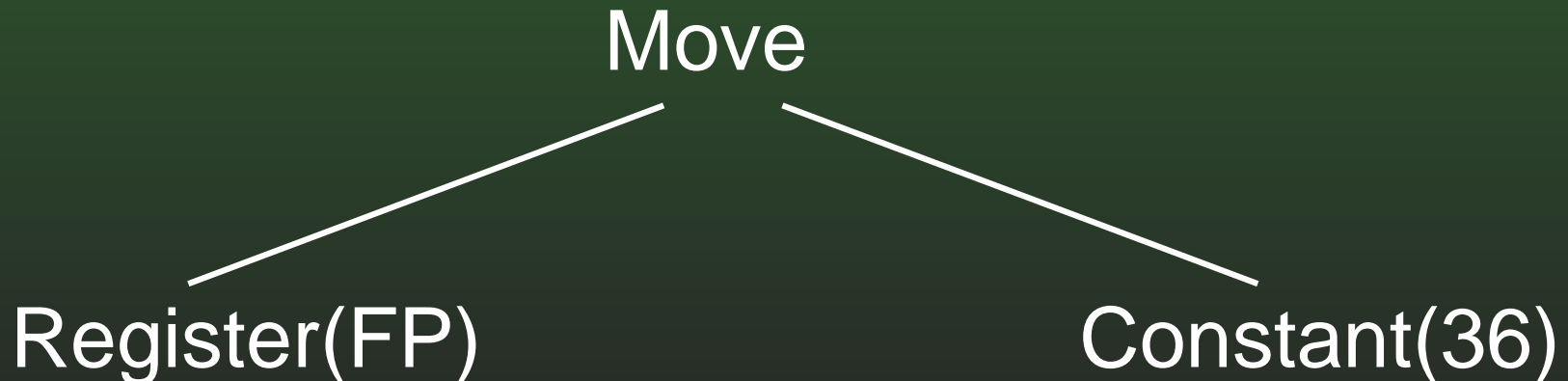

FR-105: Statement Trees

- Move Statements
 - Move statements are used to move data into either a memory location or a register
 - Left subtree of a move statement must be a register or memory expression
 - Right subtree of a move statement is any expression
 - To store the value 1 a variable that is at the beginning of the stack frame:

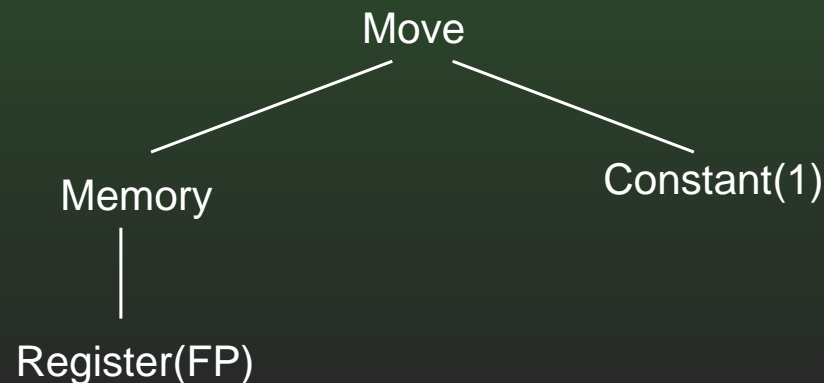

FR-106: Abstract Assembly Examples

```
void foo(int a, int b) {
    int x;
    int y;
    boolean z;

    x = 1;          <--- This statement
    y = a * b;
    y++;
    bar(y, x + 1, a);
    x = function(y+1, 3);
    if (x > 2)
        z = true;
    else
        z = false;
}
```

FR-107: Abstract Assembly Examples

x = 1;

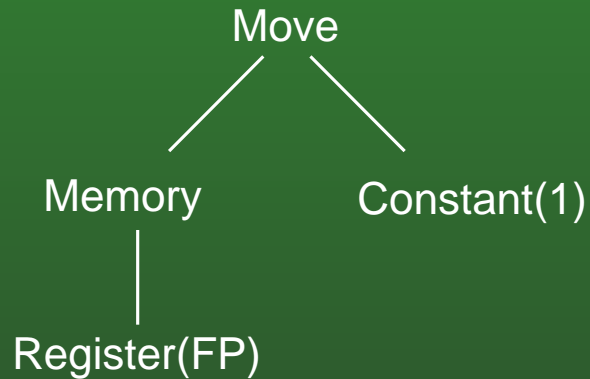

FR-108: Abstract Assembly Examples

```
void foo(int a, int b) {
    int x;
    int y;
    boolean z;

    x = 1;
    y = a * b;    <--- This statement
    y++;
    bar(y, x + 1, a);
    x = function(y+1, 3);
    if (x > 2)
        z = true;
    else
        z = false;
}
```

FR-109: Abstract Assembly Examples

$y = a * b;$

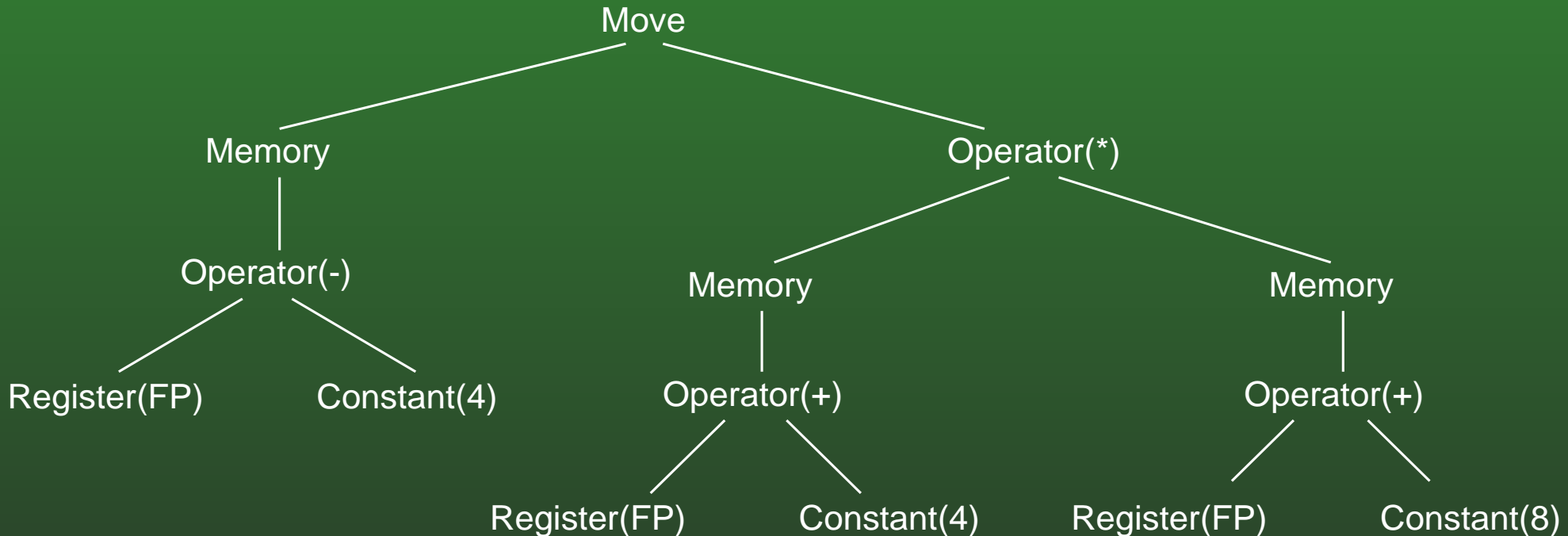

FR-110: Abstract Assembly Examples

```
void foo(int a, int b) {
    int x;
    int y;
    boolean z;

    x = 1;
    y = a * b;
    y++;          <--- This statement
    bar(y, x + 1, a);
    x = function(y+1, 3);
    if (x > 2)
        z = true;
    else
        z = false;
}
```

FR-111: Abstract Assembly Examples

`y++;`

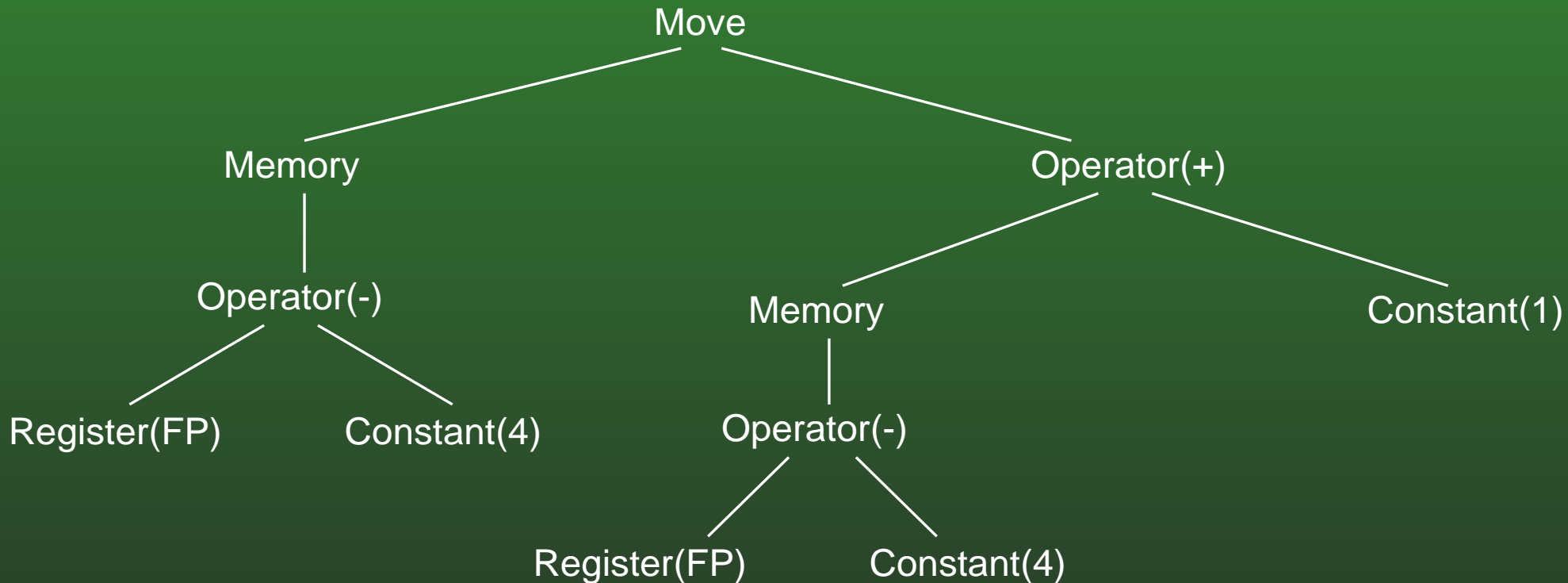

FR-112: Abstract Assembly Examples

```
void foo(int a, int b) {
    int x;
    int y;
    boolean z;

    x = 1;
    y = a * b;
    y++;
    bar(y, x + 1, a);    <--- This statement
    x = function(y+1, 3);
    if (x > 2)
        z = true;
    else
        z = false;
}
```

FR-113: Abstract Assembly Examples

```
bar(y, x + 1, a);
```

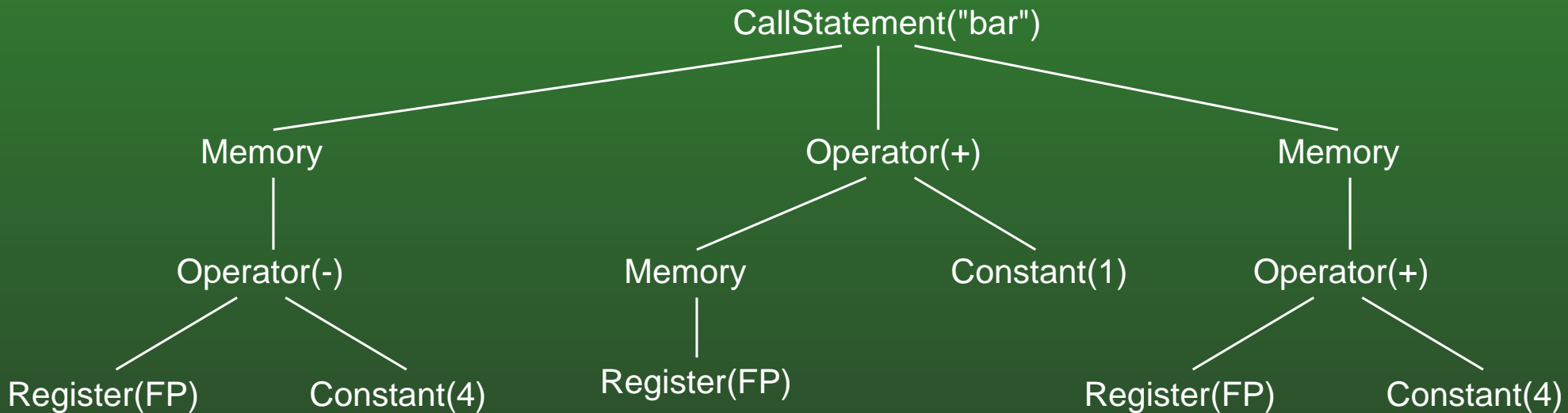

FR-114: Abstract Assembly Examples

```
void foo(int a, int b) {
    int x;
    int y;
    boolean z;

    x = 1;
    y = a * b;
    y++;
    bar(y, x + 1, a);
    x = function(y+1, 3);    <--- This statement
    if (x > 2)
        z = true;
    else
        z = false;
}
```

FR-115: Abstract Assembly Examples

```
x = function(y+1, 3);
```

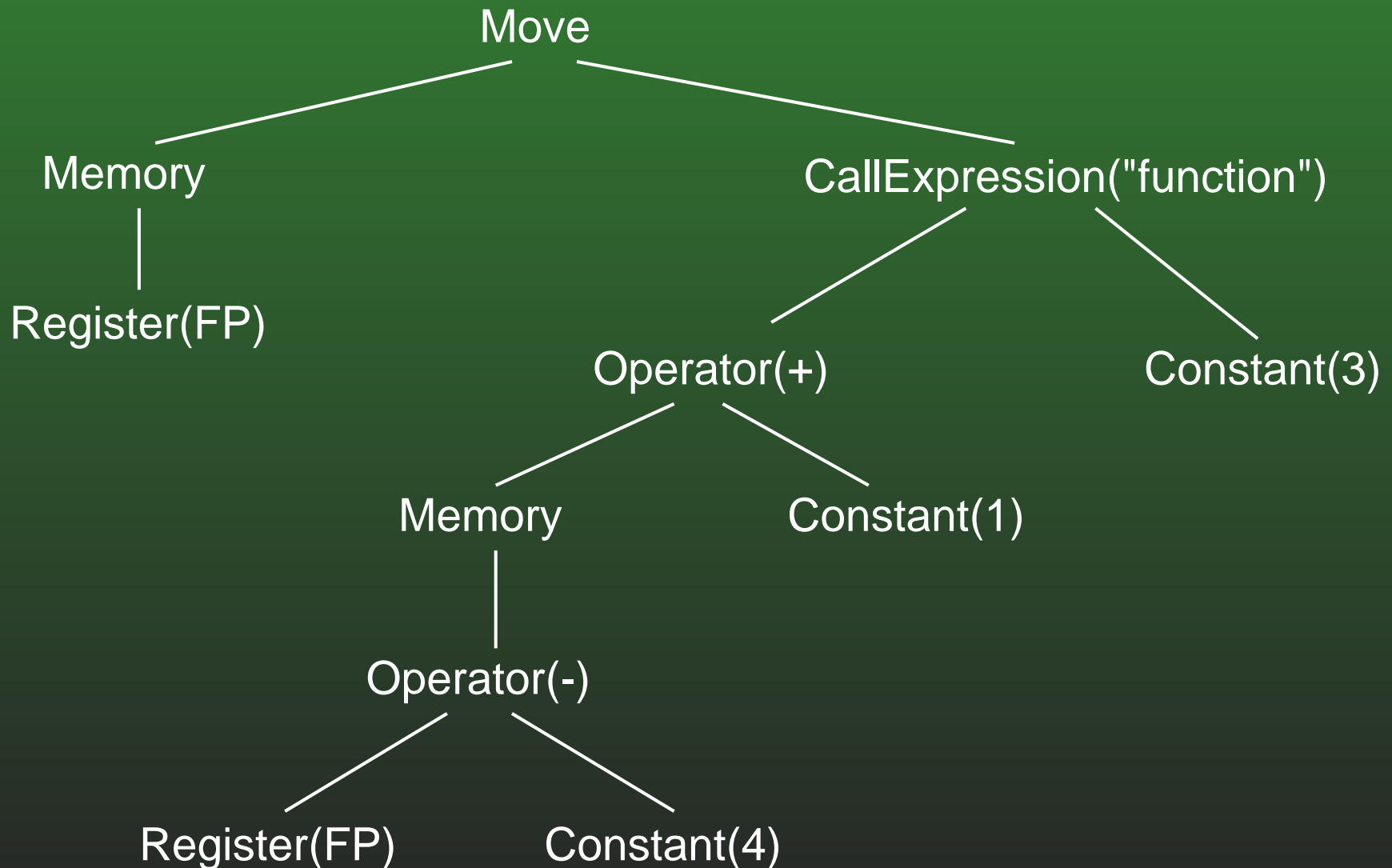

FR-116: Abstract Assembly Examples

```
void foo(int a, int b) {
    int x;
    int y;
    boolean z;

    x = 1;
    y = a * b;
    y++;
    bar(y, x + 1, a);
    x = function(y+1, 3);
    if (x > 2)          -|
        z = true;      | If statement
    else                |
        z = false;     -|
}
}
```

FR-117: Abstract Assembly Examples

```
if (x > 2) z = true; else z = false;
```

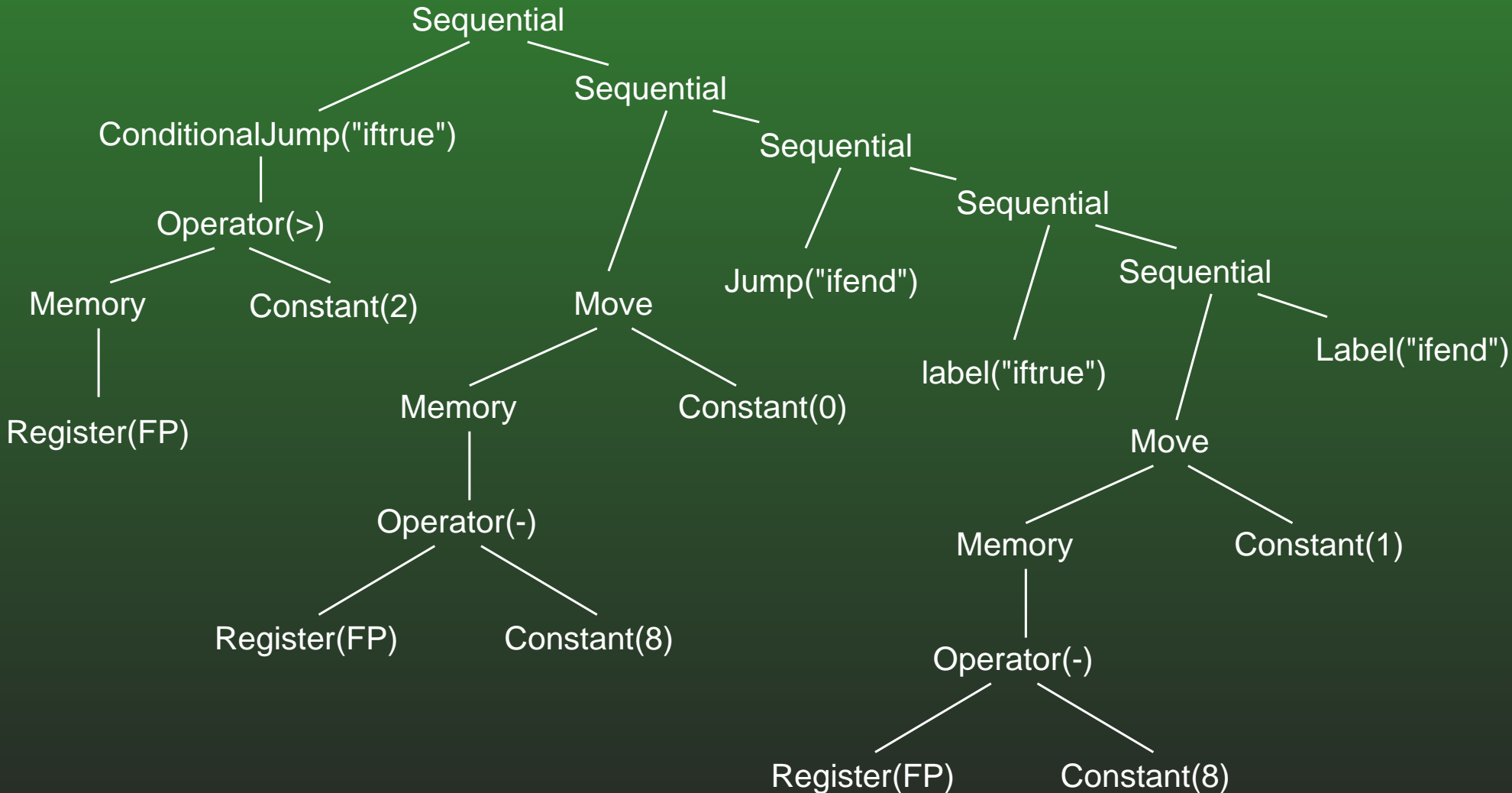

FR-118: Creating Abstract Assembly

- Array Variables (A[3], B[4][5], etc)
 - Contents of array are stored on the heap
 - Pointer to the base of the array is stored on the stack

FR-119: Array Variables

```
void arrayallocation() {  
    int x;  
    int A[] = new int[5];  
    int B[] = new int[5];  
    /* body of function */  
}
```

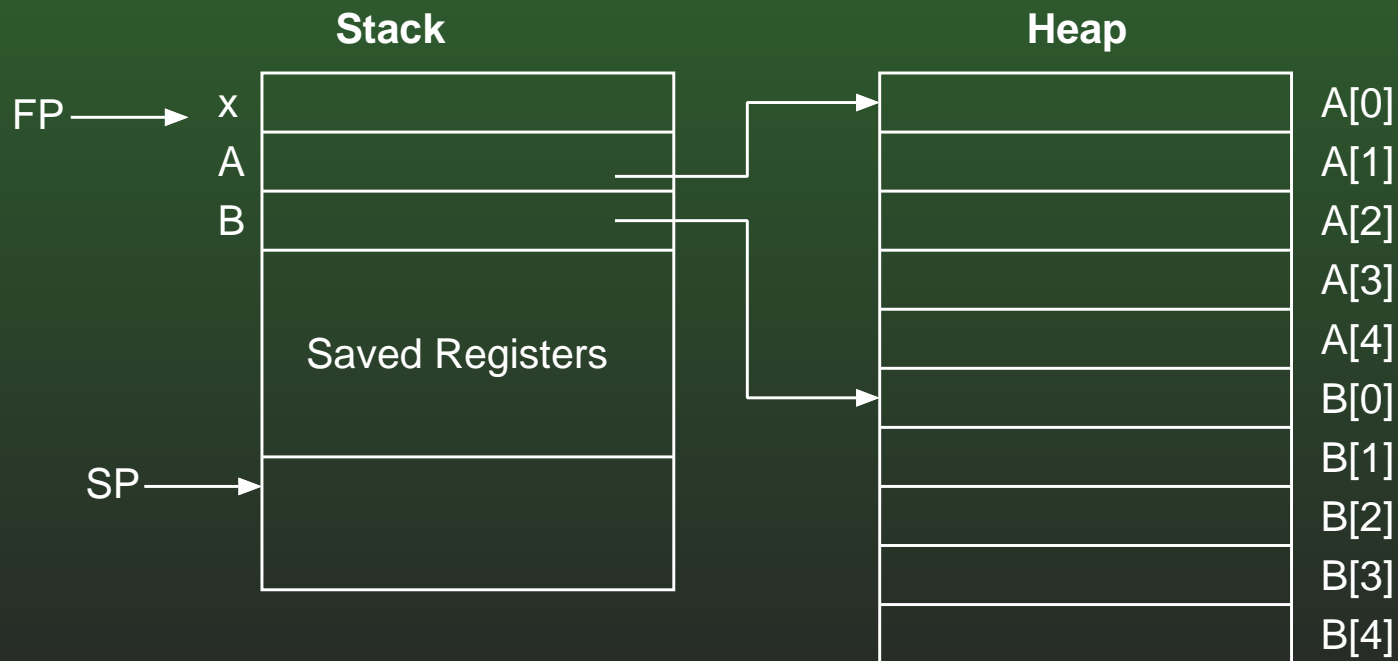

FR-120: Array Variables

- How do we represent $A[3]$ in abstract assembly?
 - Use the offset of A to get at the beginning of the array
 - Subtract $3 * (\text{element size})$ from this pointer
 - In simpleJava, all variables take a single word. Complex variables – classes and arrays – are pointers, which also take a single word
 - Heap memory works like stacks – “grow” from large addresses to small addresses
 - Dereference this pointer, to get the correct memory location

FR-121: Array Variables

- A[3]

FR-122: Array Variables

- A[3]

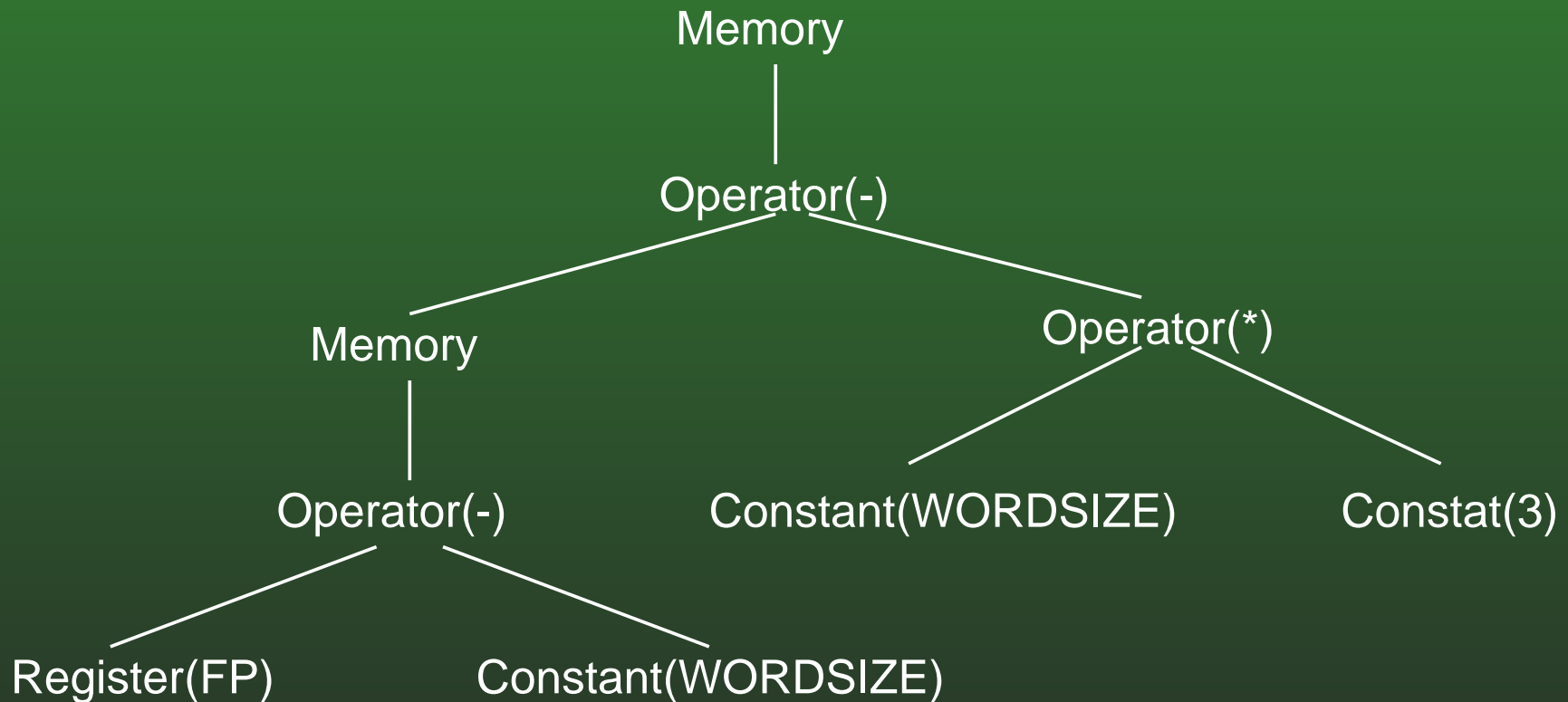

FR-123: Array Variables

- $A[x]$

FR-124: Array Variables

- $A[x]$

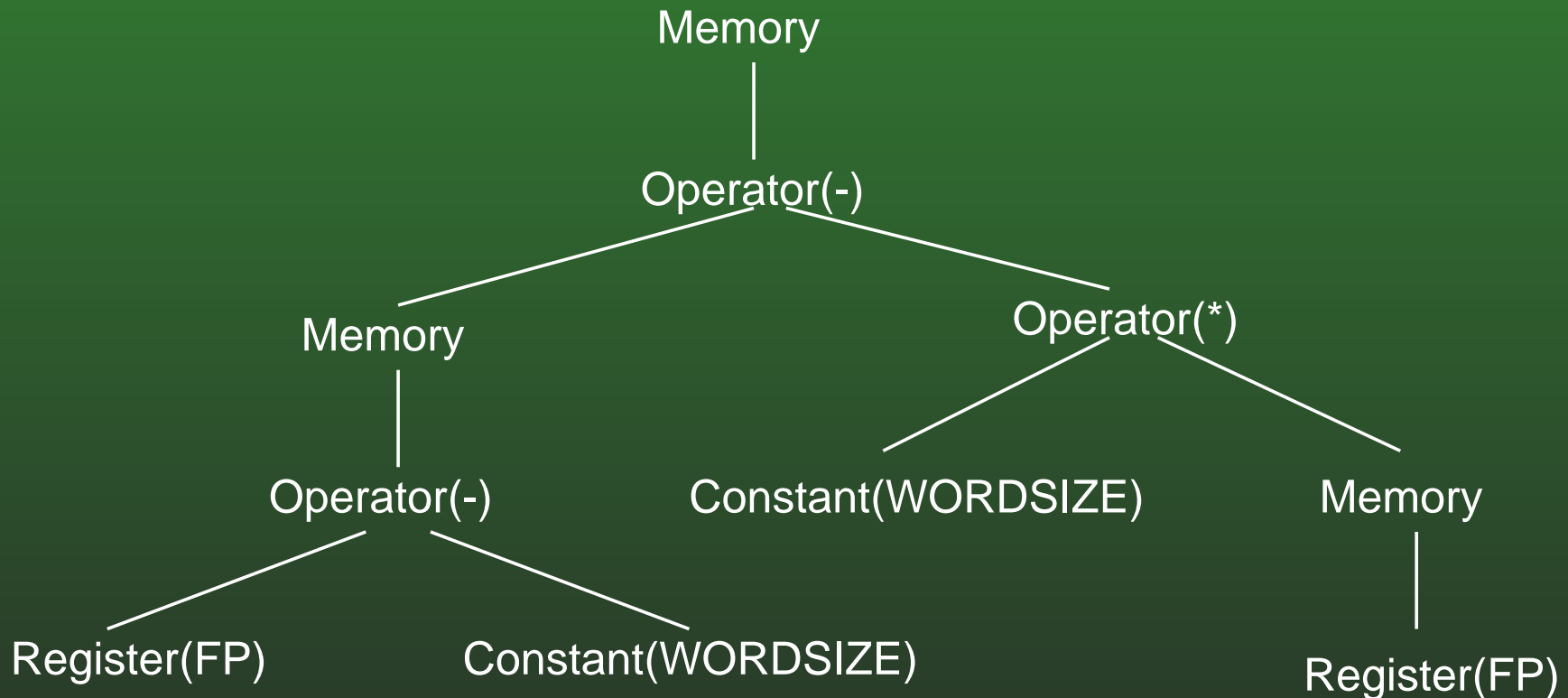

FR-125: Array Variables

- A[B[2]]

FR-126: Array Variables

- A[B[2]]

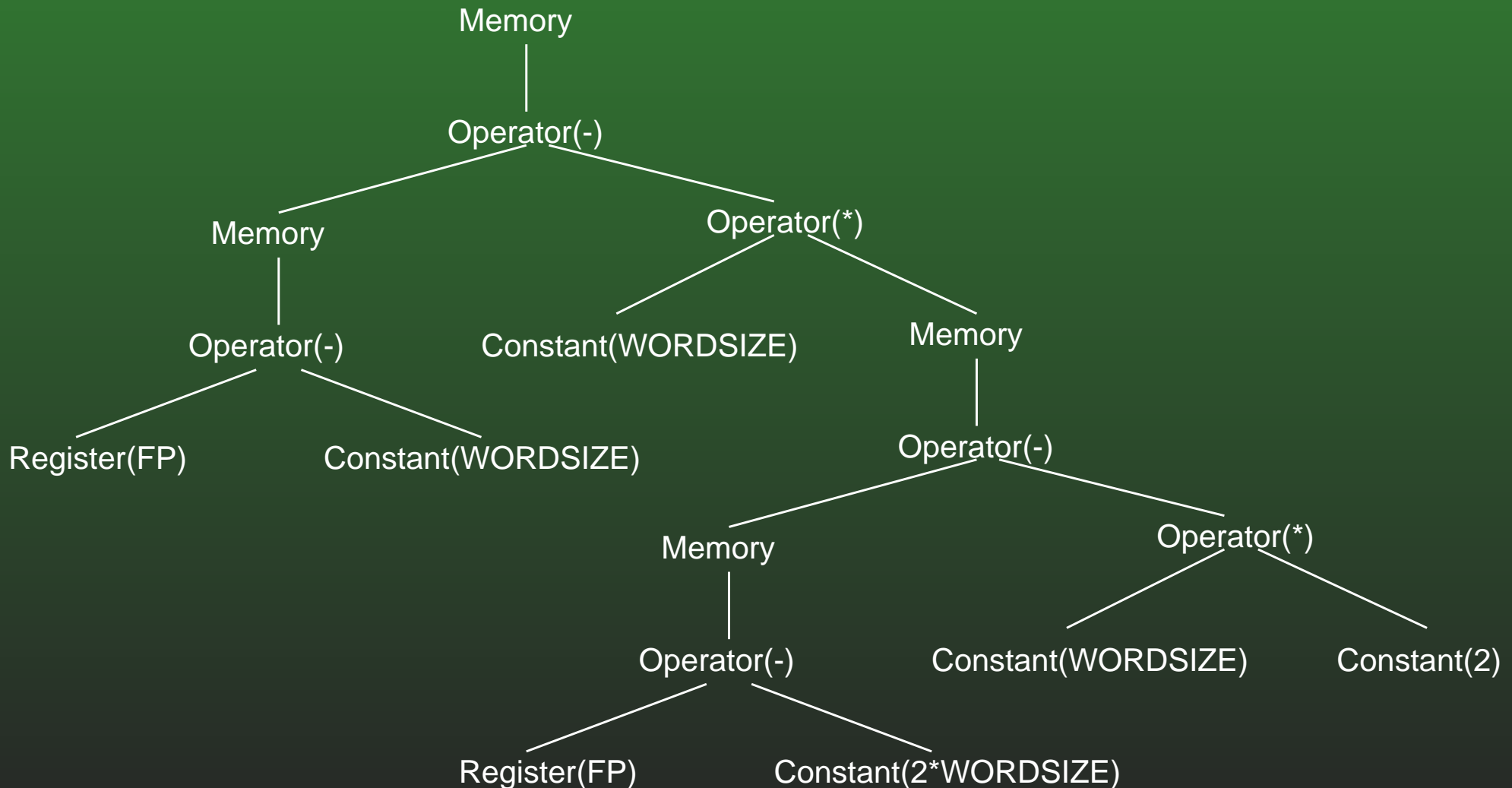

FR-127: 2D Arrays

```
void twoDarray {
    int i;
    int C[] [];

    C = new int[3] [];
    for (i=0; i<3; i++)
        C[i] = new int[2];

    /* Body of function */
}
```

FR-128: 2D Arrays

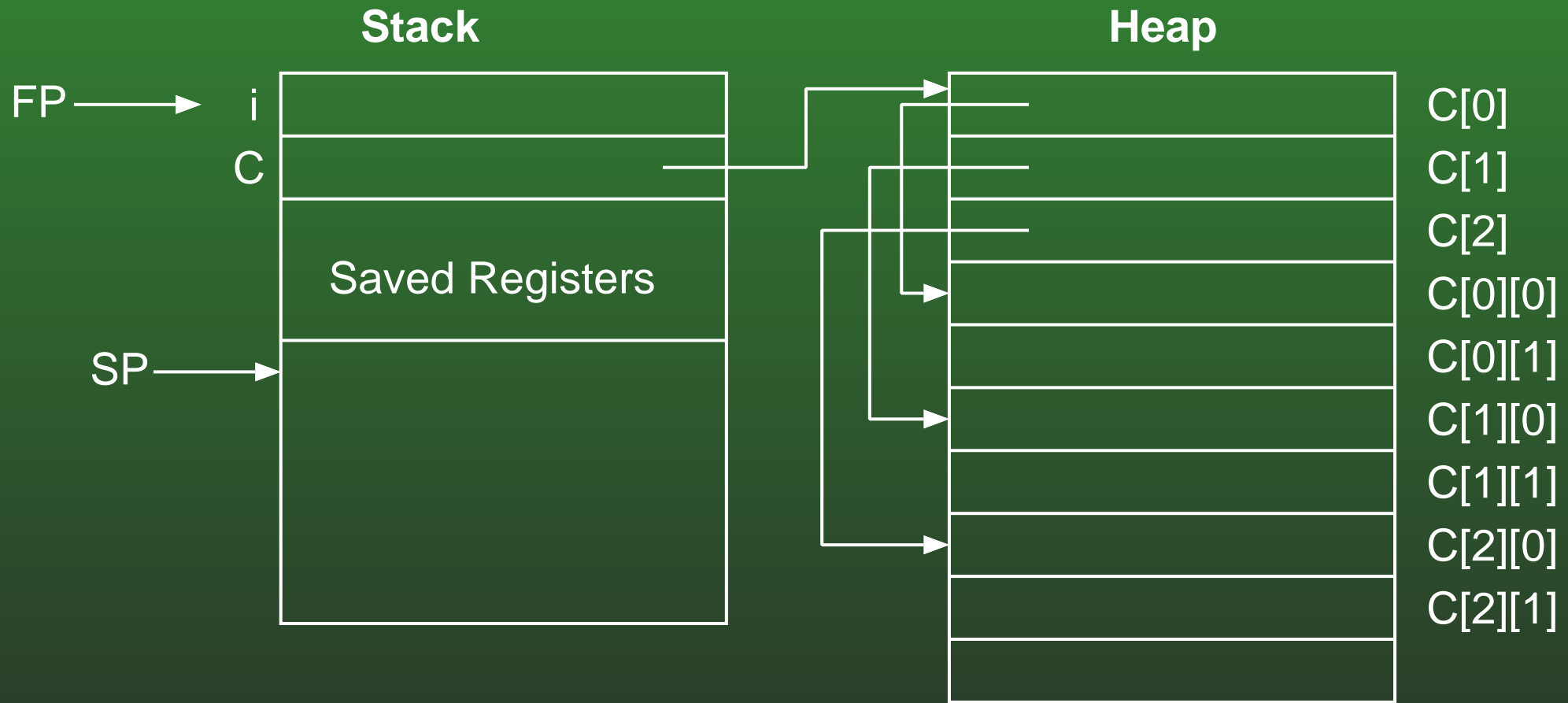

FR-129: 2D Arrays

- C

FR-130: 2D Arrays

- C

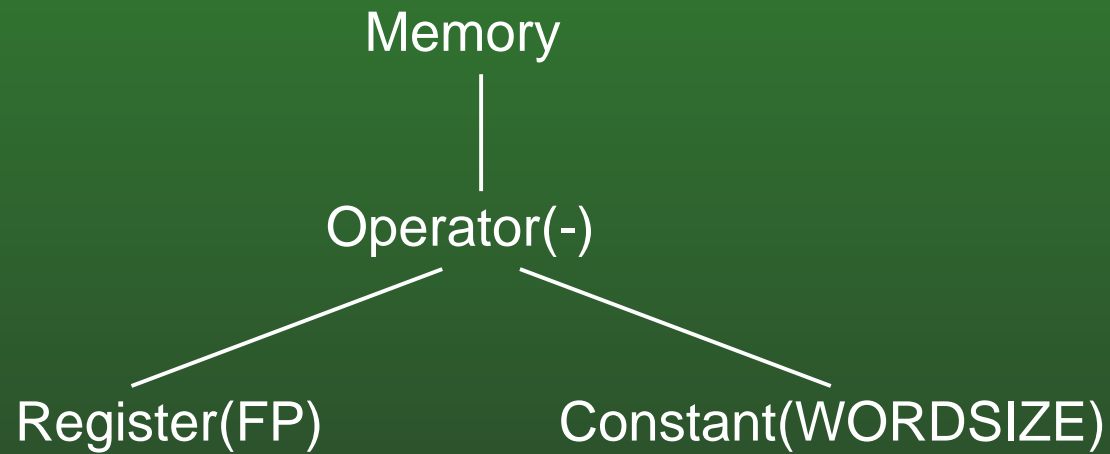

FR-131: 2D Arrays

- C[2]

FR-132: 2D Arrays

- C[2]

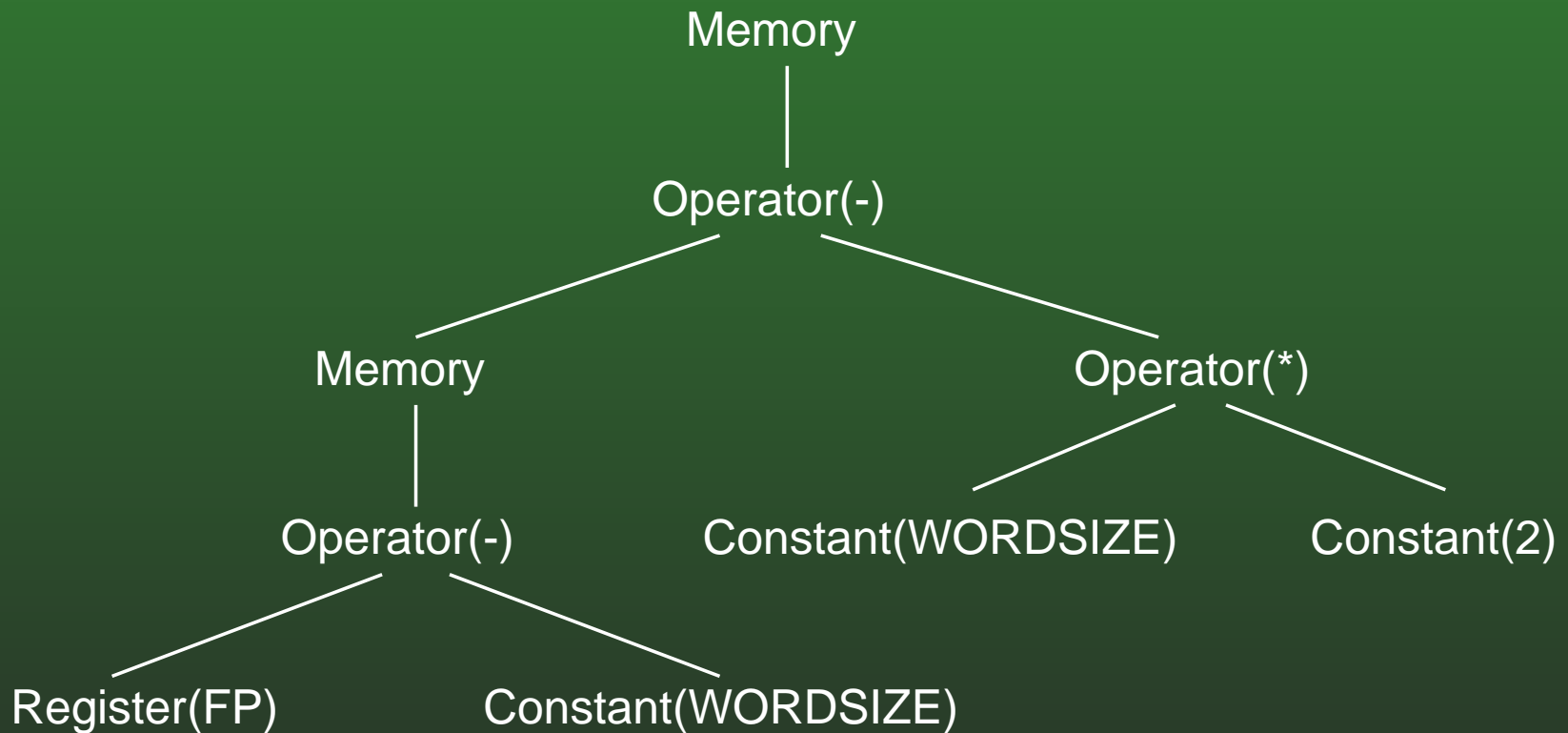

FR-133: 2D Arrays

- C[2][1]

FR-134: 2D Arrays

- C[2][1]

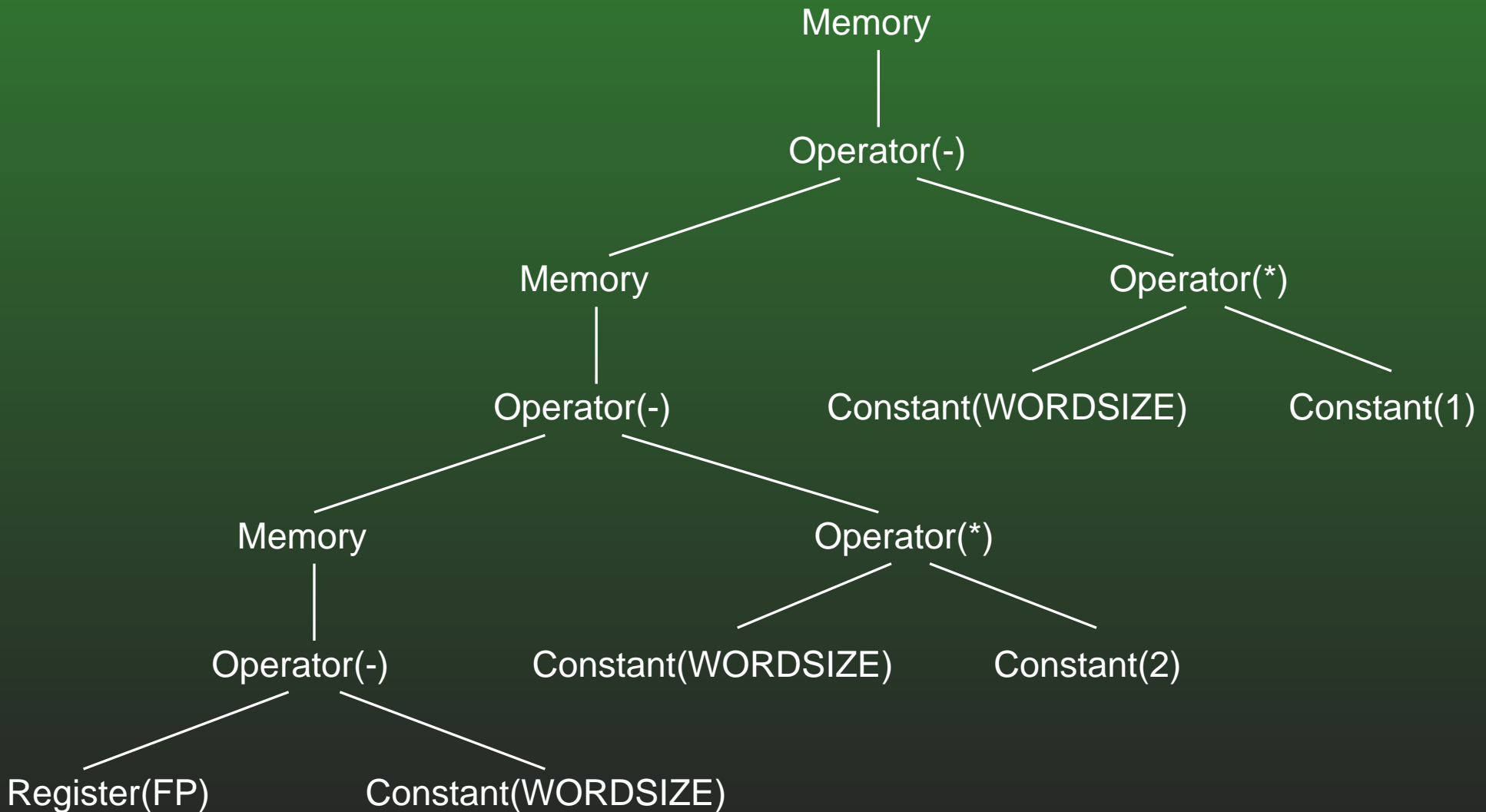

FR-135: Instance Variables

- `x.y, z.w`
- Very similar to array variables
 - Array variables – offset needs to be calculated
 - Instance variables – offset known at compile time

FR-136: Instance Variables

```
class simpleClass {
    int x;
    int y;
    int A[];
}

void main() {
    simpleClass s;
    s = new simpleClass();
    s.A = new int[3];

    /* Body of main */
}
```

FR-137: Instance Variables

- Variable `s`

FR-138: Instance Variables

- Variable s

Memory



Register(FP)

FR-139: Instance Variables

- Variable `s.y`

FR-140: Instance Variables

- Variable `s.y`

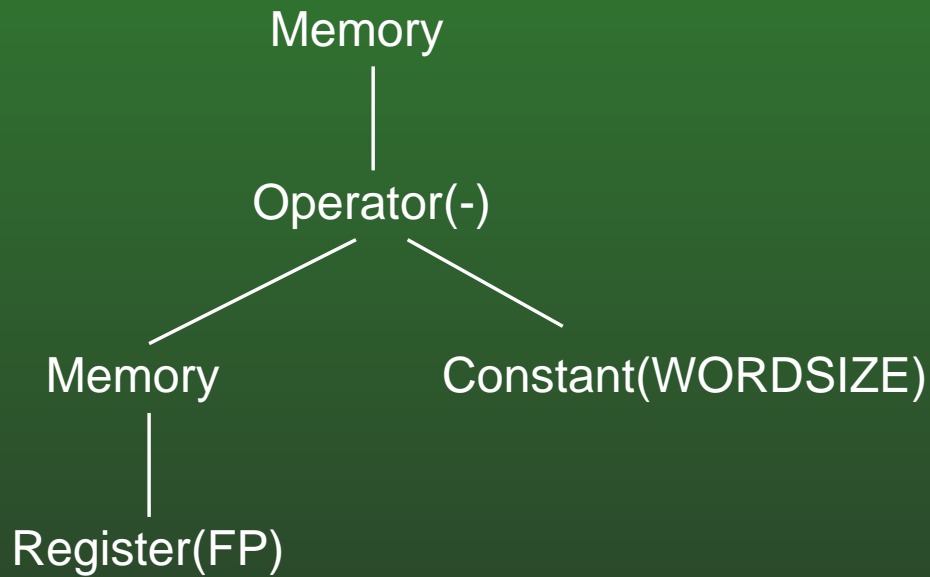

FR-141: Instance Variables

- Variable `s.x`

FR-142: Instance Variables

- Variable `s.x`

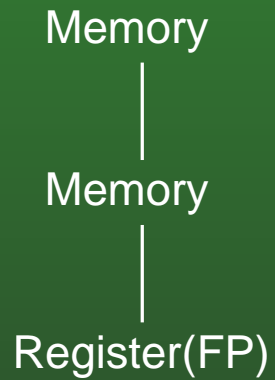

FR-143: Instance Variables

- Variable `s.A[3]`

FR-144: Instance Variables

- Variable `s.A[3]`

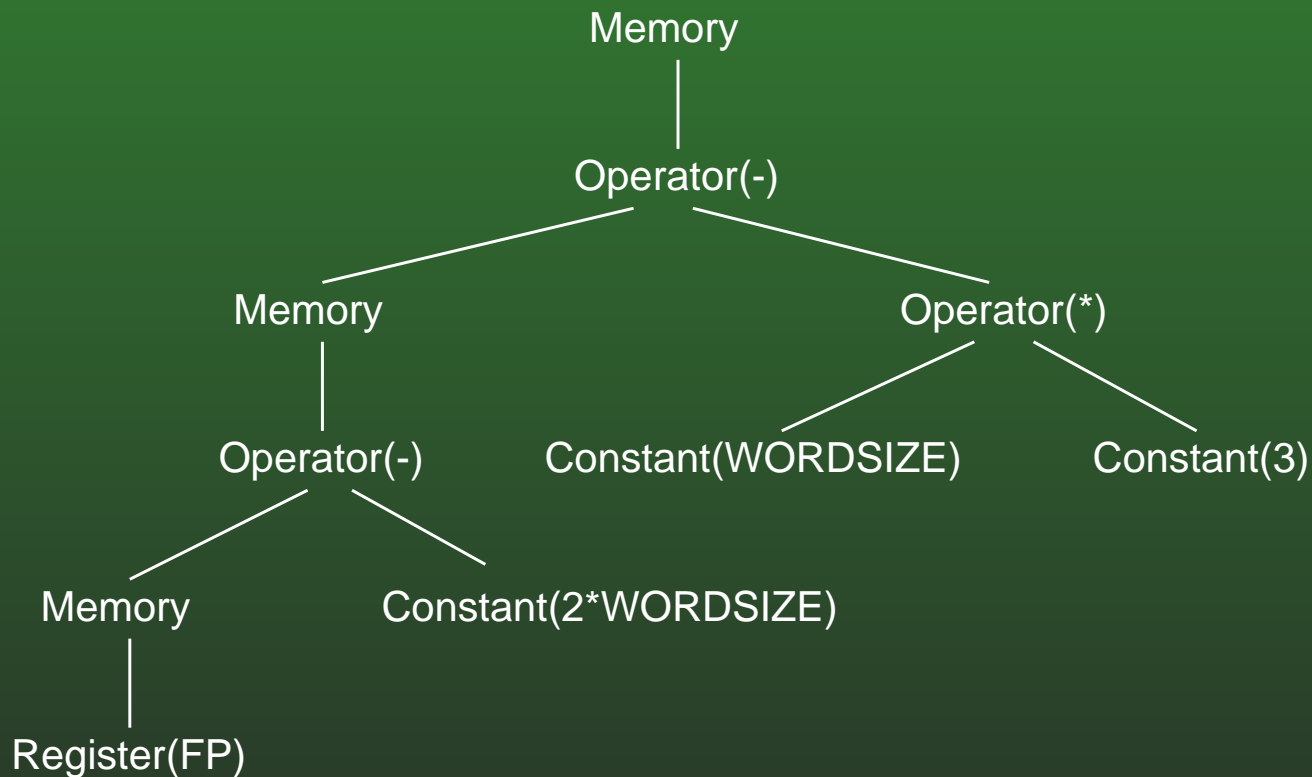

FR-145: Instance Variables

- Variable `s.A[s.y]`

FR-146: Instance Variables

- Variable $s.A[s.y]$

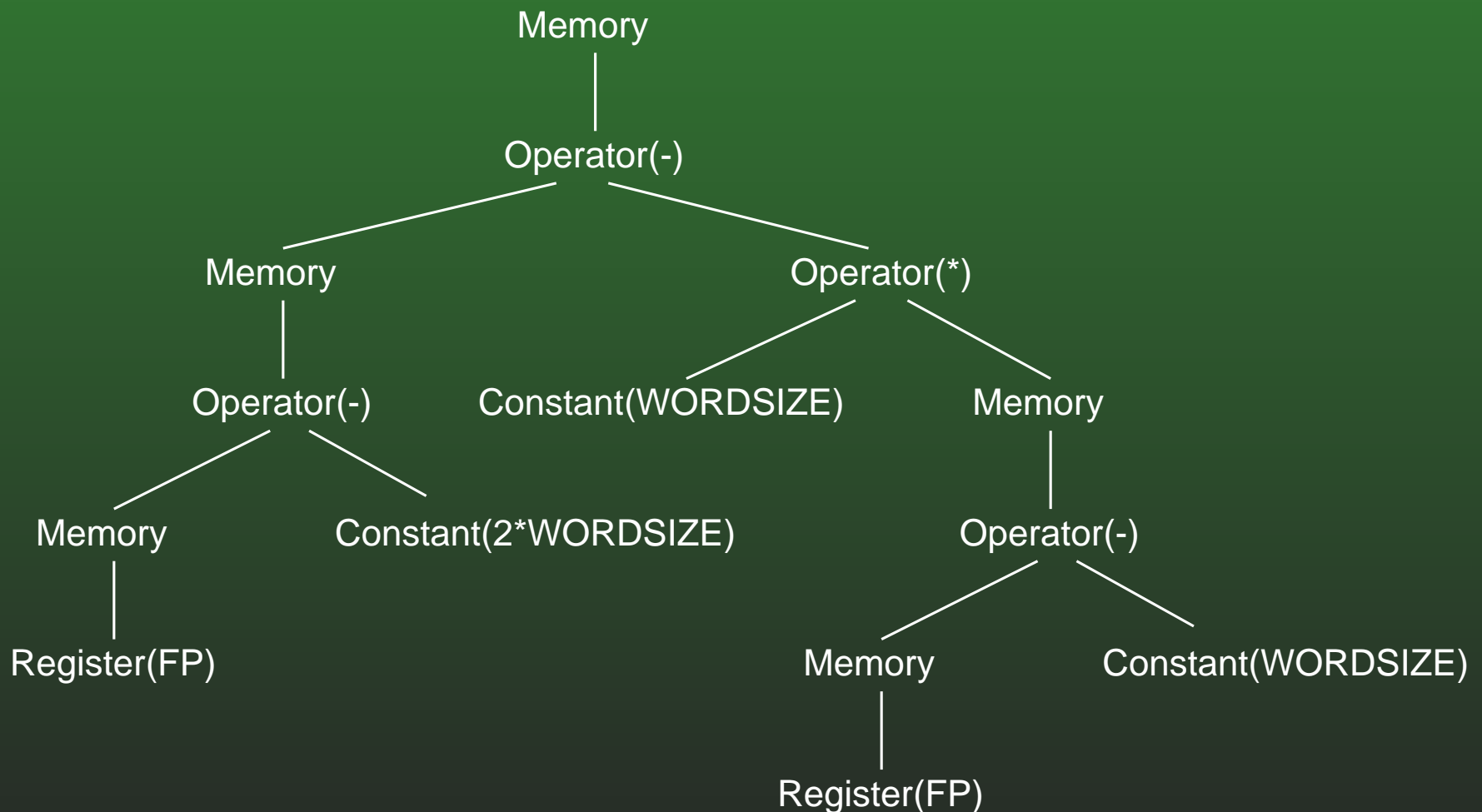

FR-147: While Statements

```
while (<test>) <statement>
```

FR-148: While Statements

```
while (<test>) <statement>
```

- Straightforward version:

```
WHILESTART:
```

```
    If (not <test>) goto WHILEEND
```

```
    < code for statement >
```

```
    goto WHILESTART
```

```
WHILEEND:
```

FR-149: While Statements

```
while (<test>) <statement>
```

- More Efficient:

```
        goto WHILETEST  
WHILESTART:  
        < code for statement >  
WHILETEST:  
        If (<test>) goto WHILESTART
```

FR-150: Code Generation

- Next Step: Create actual assembly code.
- Use a tree tiling strategy:
 - Create a set of tiles with associated assembly code.
 - Cover the AST with these tiles.
 - Output the code associated with each tiles.
- As long as we are clever about the code associated with each tile, and how we tile the tree, we will create correct actual assembly.

FR-151: Tree Tilings

- We will explore several different tree tiling strategies:
 - Simple tiling, that is easy to understand but produces inefficient code
 - More complex tiling, that relies less on the expression stack
 - Modifications to complex tilings, to increase efficiency

FR-152: Simple Tiling

- Based on a post-order traversal of the tree
- Cover the tree with tiles
 - Each tile associated with actual assembly
- Emit the code associated with the tiles in a left-to-right, post-order traversal of the tree

FR-153: Simple Tiling

- Expression Trees
 - The code associated with an expression tree will place the value of that expression on the top of the expression stack

FR-154: Expression Trees

- Arithmetic Binary Operations

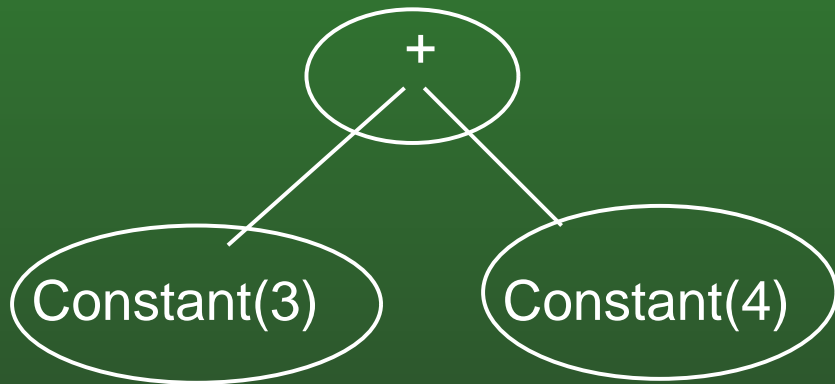

- What should the code for the + tile be?
 - Code for entire tree needs to push *just* the final sum on the stack
 - Code for Constant Expressions push constant values on top of the stack

FR-155: Expression Trees

- Arithmetic Binary Operations
 - Code for a “+” tile:

```
lw    $t1, 8($ESP)    % load first operand
lw    $t2, 4($ESP)    % load the second operand
add   $t1, $t1, $t2   % do the addition
sw    $t1, 8($ESP)    % store the result
add   $ESP, $ESP, 4   % update the ESP
```

FR-156: Expression Trees

- Memory Accesses
 - Memory node is a memory dereference
 - Pop operand into a register
 - Dereference register
 - Push result back on stack

FR-157: Expression Trees

- Memory Accesses

```
lw $t1, 4($ESP)
```

```
lw $t1, 0($t1)
```

```
sw $t1, 4($ESP)
```

FR-158: Expression Trees

- Memory Example

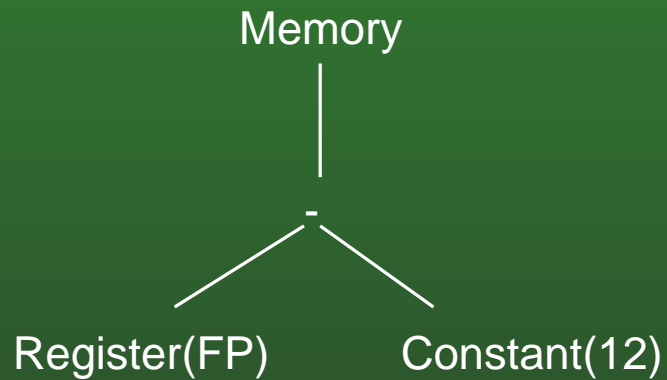

FR-159: Expression Trees

- Memory Example

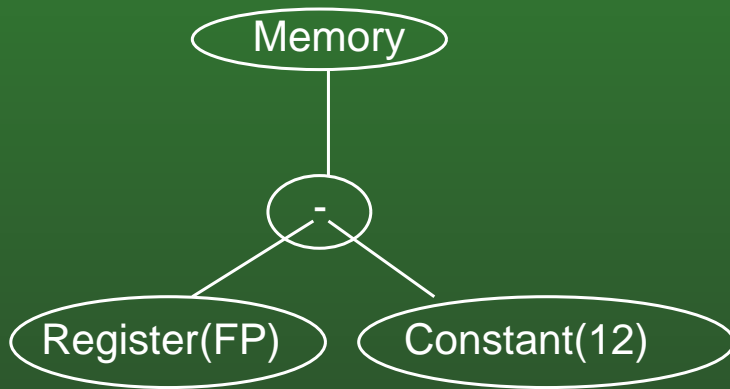

FR-160: Expression Trees

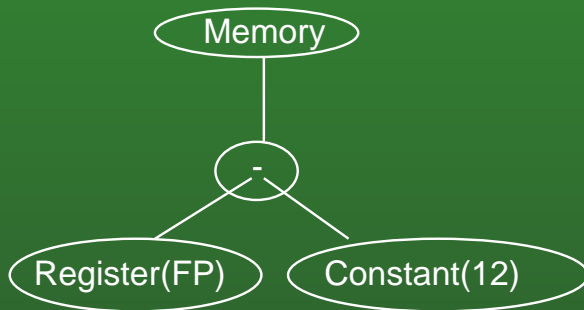

```
sw    $FP, 0($ESP)    % Store frame pointer on the top of the expressin stack
addi  $ESP, $ESP, -4  % Update the expression stack pointer
addi  $t1, $zero, 12  % Load the constant value 12 into the register $t1
sw    $t1, 0($ESP)    % Store $t1 on the top of the expression stack
addi  $ESP, $ESP, -4  % update the expression stack pointer
lw    $t1, 4($ESP)    % load the first operand into temporary $t1
lw    $t2, 8($ESP)    % load the second operand into temporary $t2
sub   $t1, $t1, $t2   % do the subtraction, storing result in $t1
sw    $t1, 8($ESP)    % store the result on the expression stack
add   $ESP, $ESP, 4   % update the expression stack pointer
lw    $t1, 4($ESP)    % Pop the address to dereference off the top of
                        % the expression stack
lw    $t1, 0($t1)     % Dereference the pointer
sw    $t1, 4($ESP)    % Push the result back on the expression stack
```

FR-161: Simple Tiling

- Statement Trees
 - The code associated with a statement tree implements the statement described by the tree

FR-162: Statement Trees

- Move Trees (Moving into MEMORY locations)

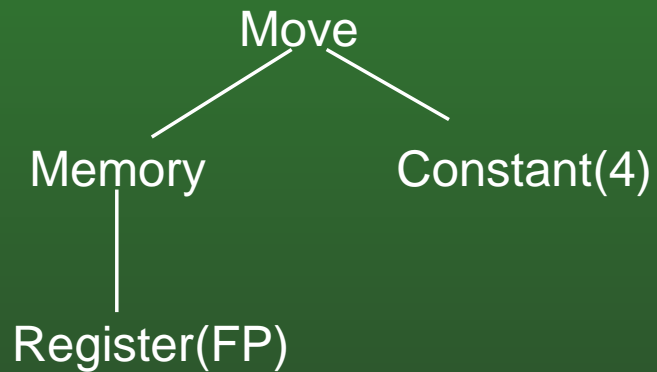

FR-163: Statement Trees

- Move Trees (Moving into MEMORY locations)

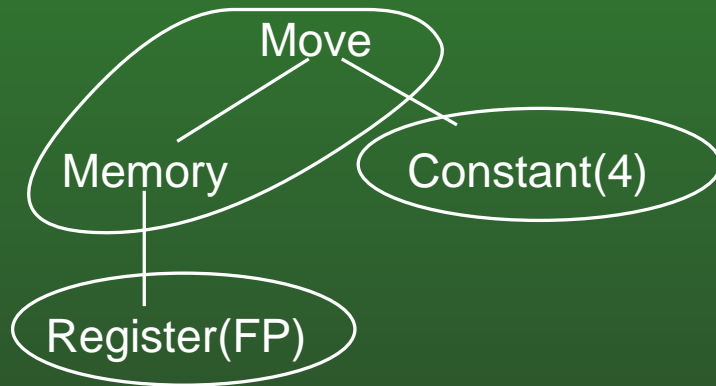

- The code for the MOVE tile needs to:
 - Pop the value to move off the stack
 - Pop the destination of the move off the stack
 - Store the value in the destination

FR-164: Statement Trees

- Move Trees (Moving into MEMORY locations)

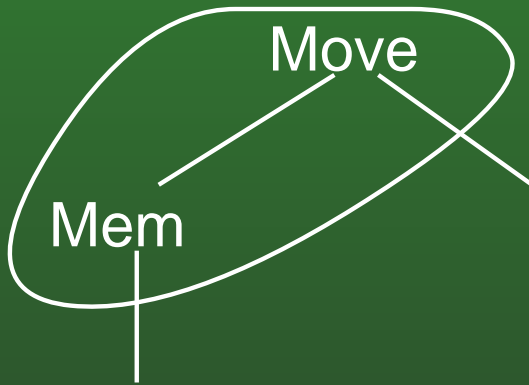

```
lw    $t1,    8($ESP)
lw    $t2,    4($ESP)
sw    $t2,    0($t1)
addi  $ESP,   $ESP, 8
```

FR-165: Statement Trees

- Move Trees (Moving into MEMORY locations)

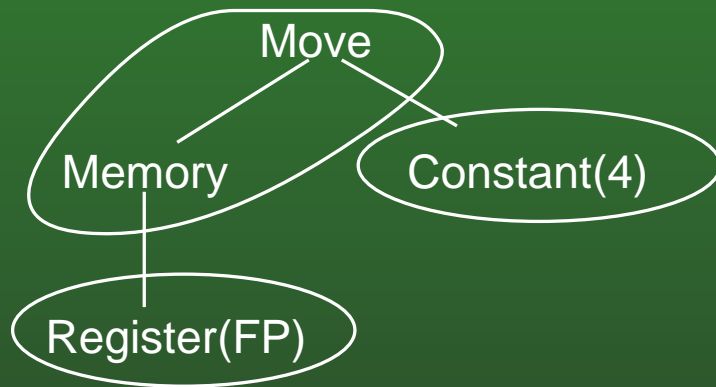

```
sw    $FP, 0($ESP)    % Store the frame pointer on the expression stack
addi  $ESP, $ESP, -4  % Update the expression stack pointer
addi  $t1, $ZERO, 4   % Put constant 4 into a register
sw    $t1, 0($ESP)    % Store register on the expression stack
addi  $ESP, $ESP, -4  % Update expression stack pointer
lw    $t1, 8($ESP)    % Store the address of the lhs of the move in a register
lw    $t2, 4($ESP)    % Store value of the rhs of the move in a register
sw    $t2, 0($t1)     % Implement the move
addi  $ESP, $ESP, 8   % update the expression stack pointer
```

FR-166: Improved Tiling

- Tiling we've seen so far is correct – but inefficient
 - Generated code is much longer than it needs to be
 - Too heavy a reliance on the stack (main memory accesses are slow)
- We can improve our tiling in three ways:

FR-167: Improved Tiling

- Decrease reliance on the expression stack
- Use large tiles
- Better management of the expression stack
 - Including storing the bottom of the expression stack in registers

FR-168: Accumulator Register

- Code for expression trees will no longer place the value on the top of the expression stack
- Instead, code for expression trees will place the value of the expression in an accumulator register (ACC)
- Stack will still be necessary (in some cases) to store partial values

FR-169: Accumulator Register

- Constant trees
 - Tree: Constant(15)
 - Code:

```
addi $ACC, $zero, 15
```

FR-170: Accumulator Register

- Binary Operators (+, -, *, etc)
 - Use an INORDER traversal instead
 - Emit code for left subtree
 - Store this value on the stack
 - Emit code for the right subtree
 - Pop value of left operand off stack
 - Do the operation, storing result in ACC

FR-171: Accumulator Register

- Binary Operators (+, -, *, etc)

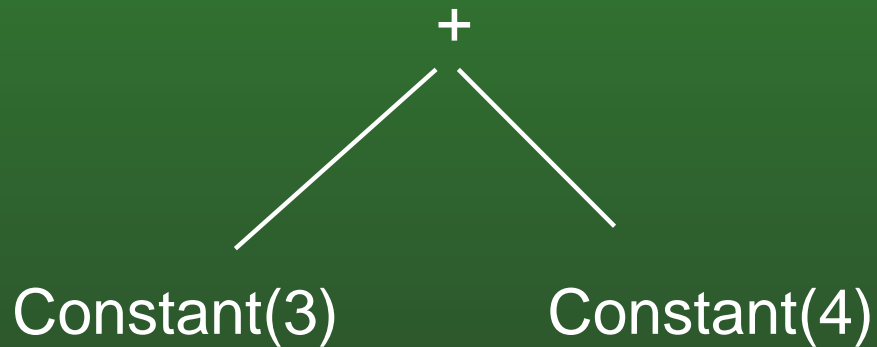

FR-172: Accumulator Register

- Binary Operators (+, -, *, etc)

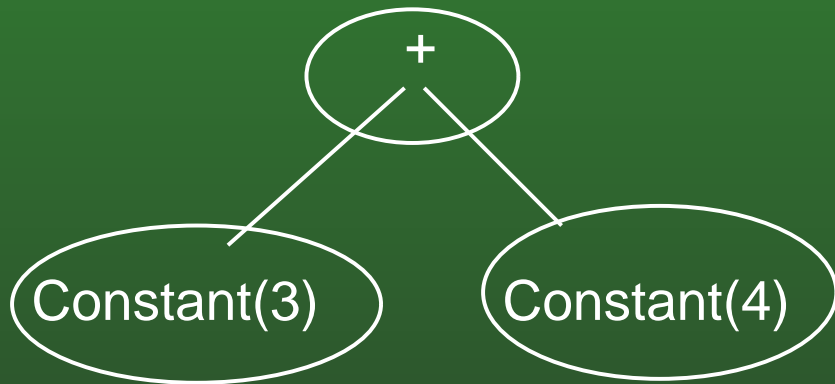

- Emit code for left subtree
- Push value on stack
- Emit code for right subtree
- Do arithmetic, storing result in ACC

FR-173: Accumulator Register

- Binary Operators (+, -, *, etc)

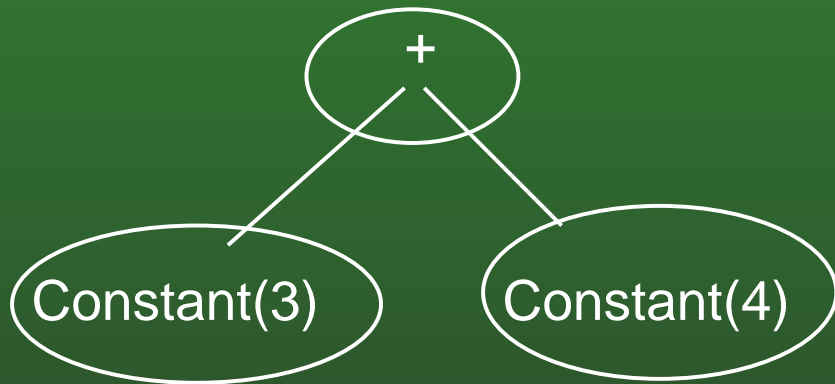

<code for left operand>

```
sw    $ACC, 0($ESP)
```

```
addi  $ESP, $ESP, -4
```

<code for right operand>

```
lw    $t1, 4($ESP)
```

```
addi  $ESP, $ESP, 4
```

```
add   $ACC, $t1, $ACC
```

FR-174: Accumulator Register

- Binary Operators (+, -, *, etc)

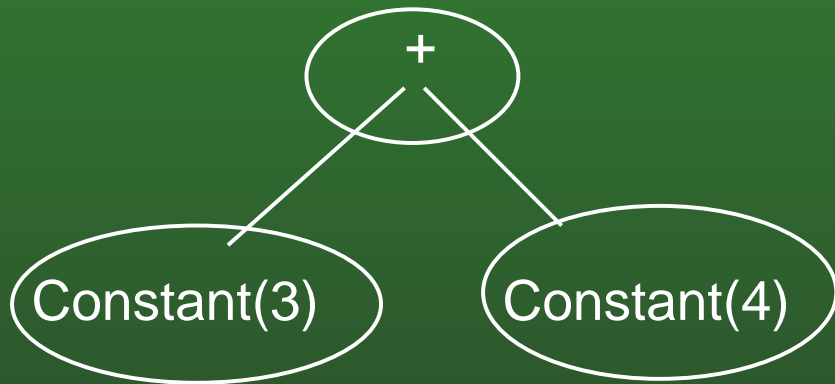

```
addi $ACC, $zero, 3
sw   $ACC, 0($ESP)
addi $ESP, $ESP, -4
addi $ACC, $zero, 4
lw   $t1, 4($ESP)
addi $ESP, $ESP, 4
add  $ACC, $t1, $ACC
```

FR-175: Larger Tiles

- Instead of covering a single node for each tile, cover several nodes with the same tile
- As long as the code associated with the larger tile is more efficient than the code associated with all of the smaller tiles, we gain efficiency

FR-176: Larger Tiles Example

- Memory Move Expression

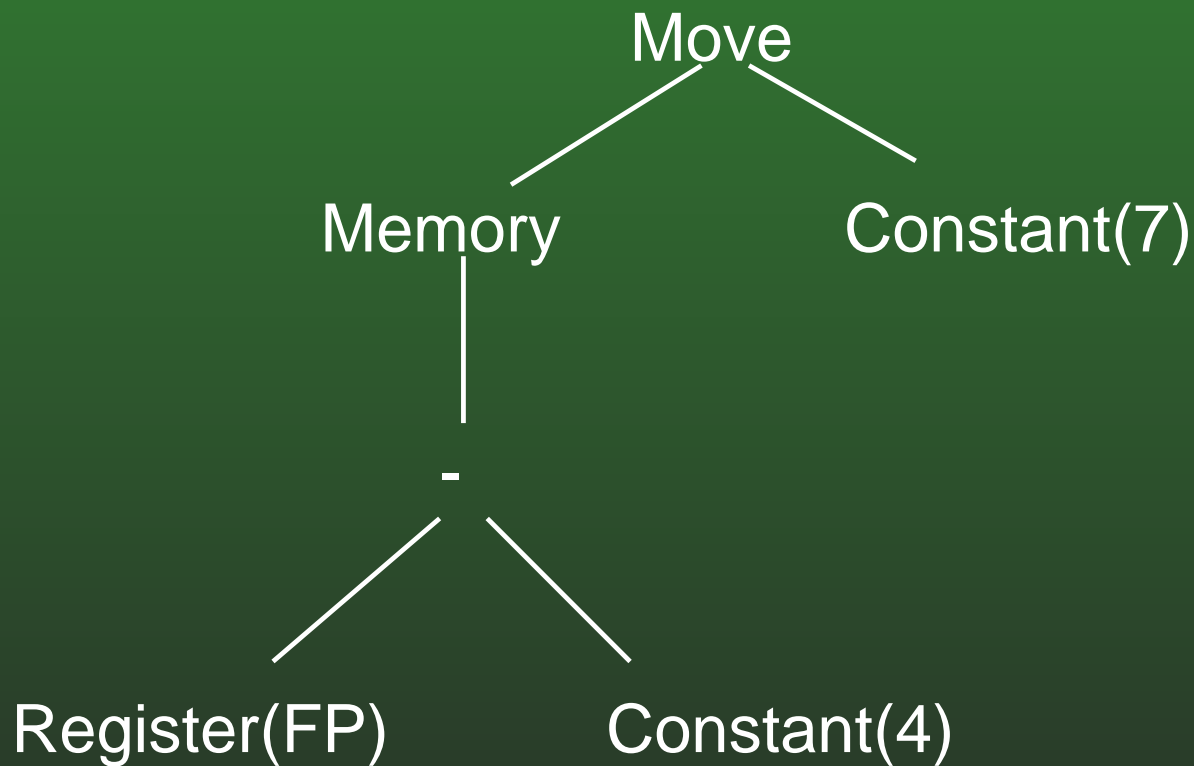

FR-177: Larger Tiles Example

- Standard Tiling

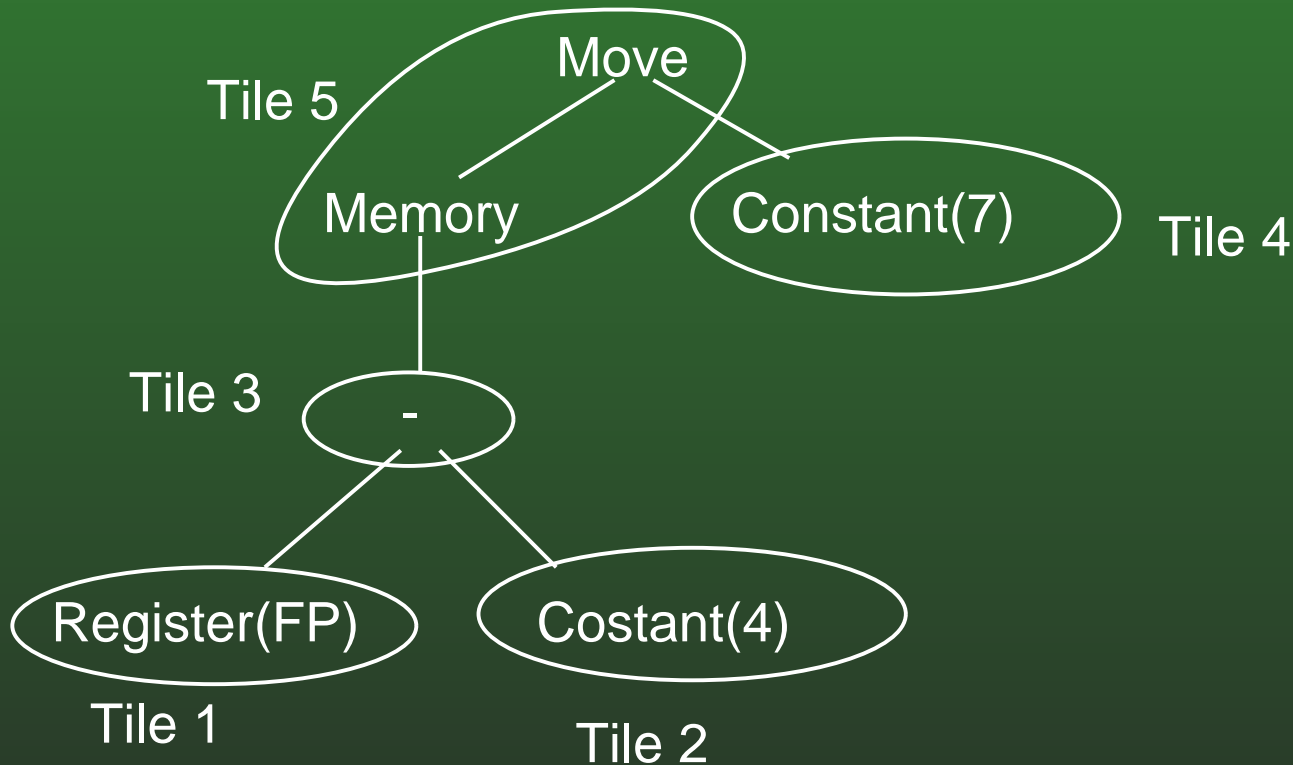

FR-178: Larger Tiles Example

- Standard Tiling

```
addi  $ACC, $FP, 0      % code for tile 1
sw    $ACC, $ESP, 0     % code for tile 3
addi  $ESP, $ESP, -4   % code for tile 3
addi  $ACC, $zero, 4   % code for tile 2
lw    $t1, 4($ESP)     % code for tile 3
addi  $ESP, $ESP, 4    % code for tile 3
sub   $ACC, $t1, $ACC  % code for tile 3
sw    $ACC, $ESP, 0     % code for tile 5
addi  $ESP, $ESP, -4   % code for tile 5
addi  $ACC, $zero, 7   % code for tile 4
lw    $t1, 4($ESP)     % code for tile 5
addi  $ESP, $ESP, 4    % code for tile 5
sw    $ACC, 0($t1)     % code for tile 5
```

FR-179: Larger Tiles Example

- Memory Move Expression

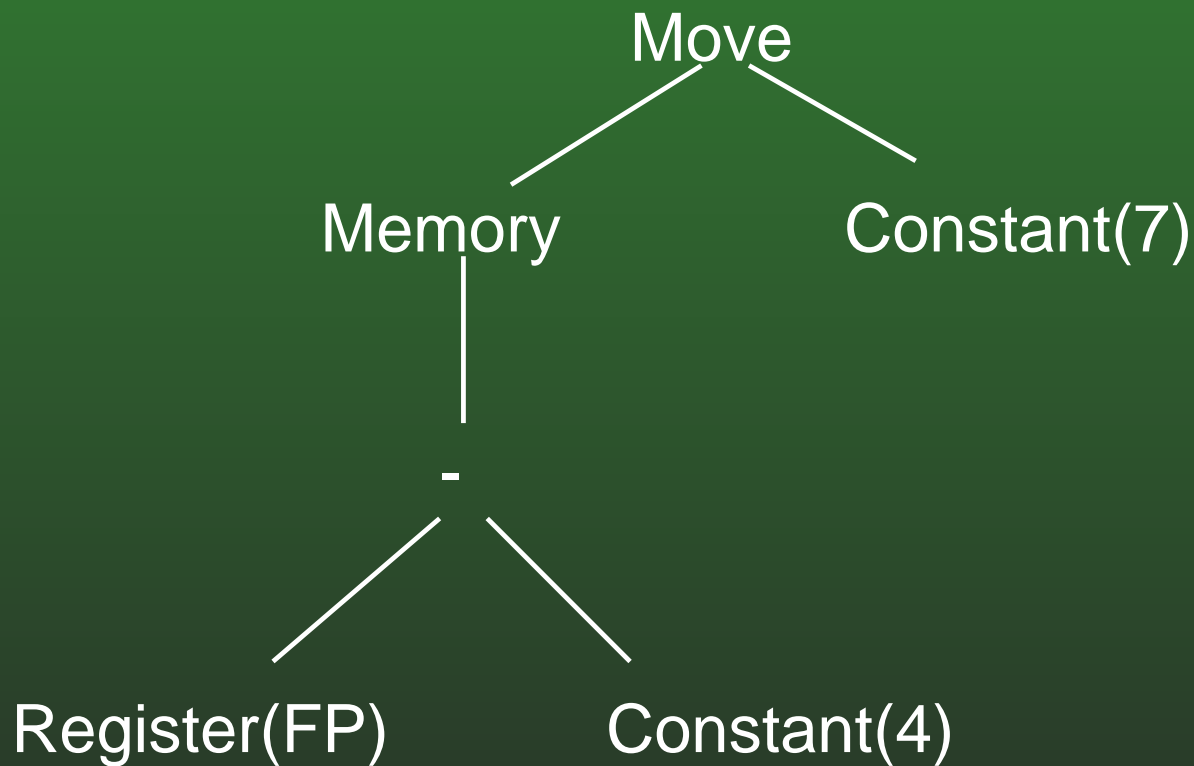

FR-180: Larger Tiles Example

- Using Larger Tiles

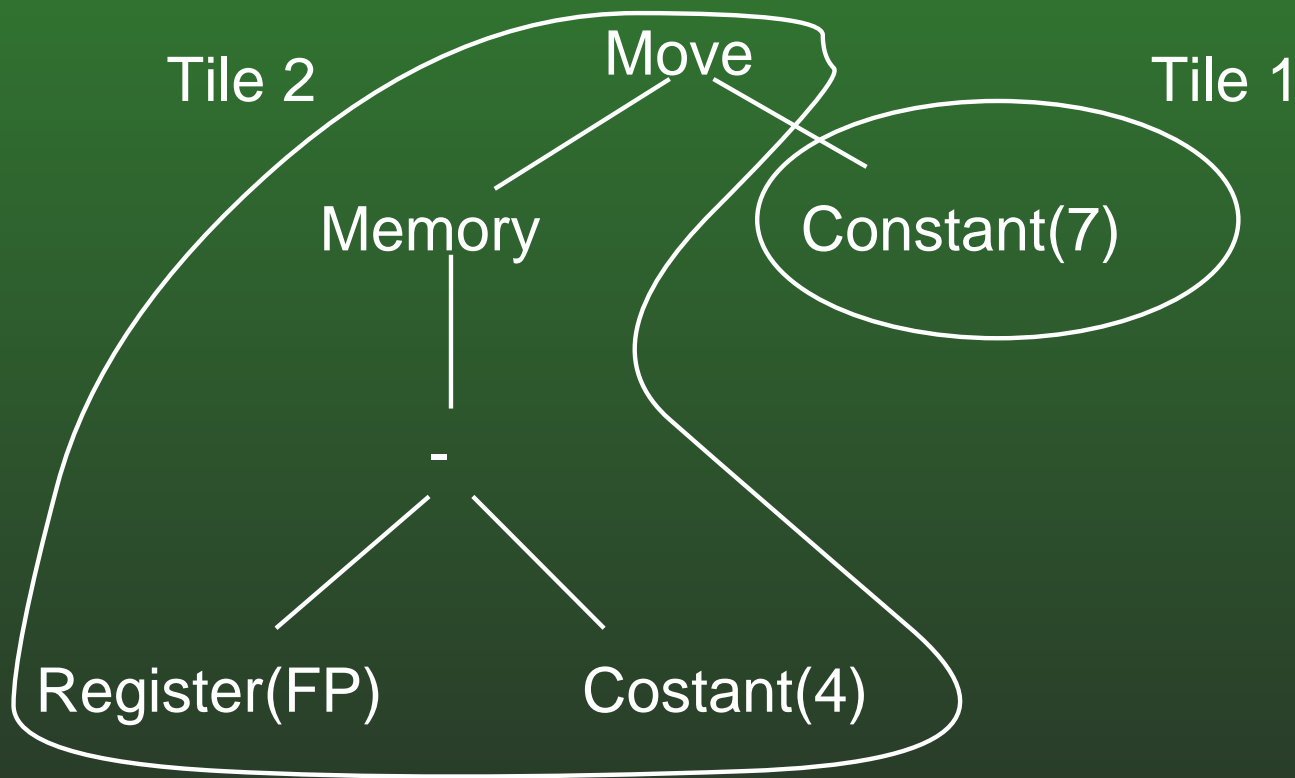

FR-181: Larger Tiles Example

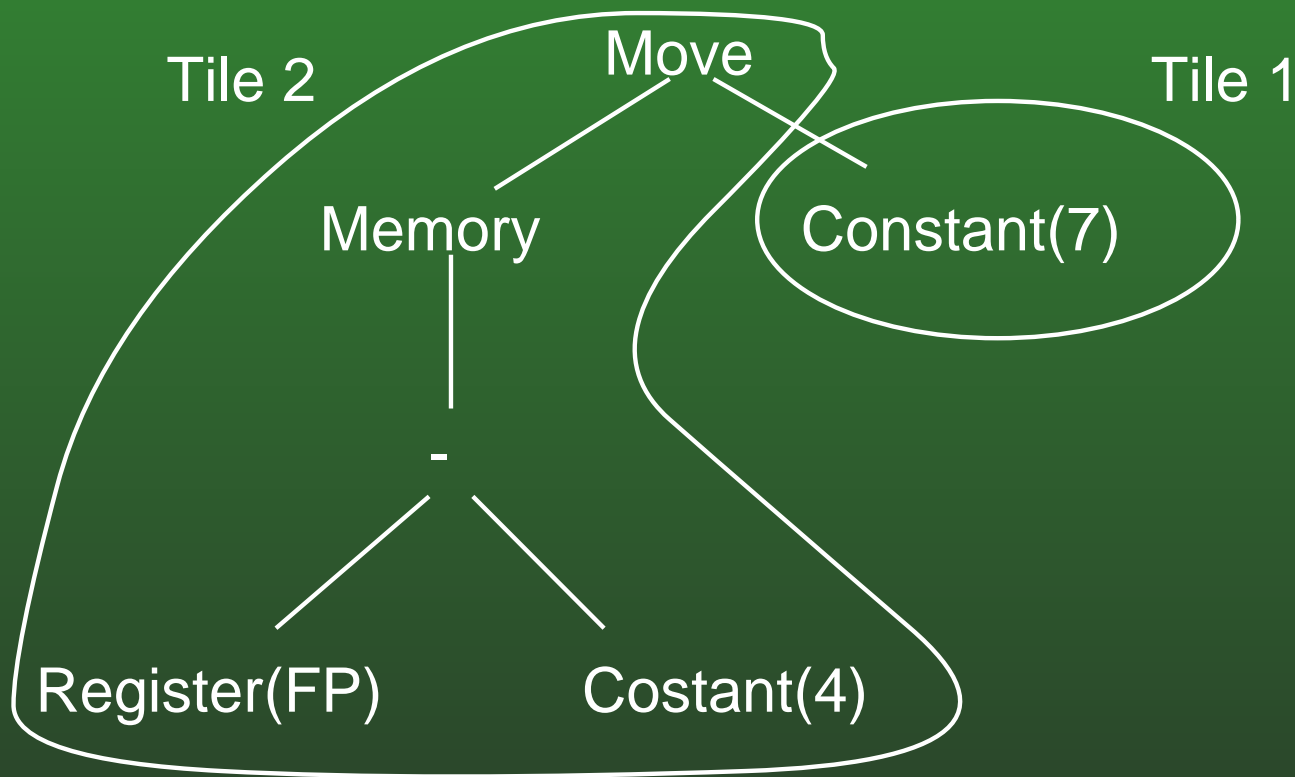

- Code for Tile 2?

FR-182: Larger Tiles Example

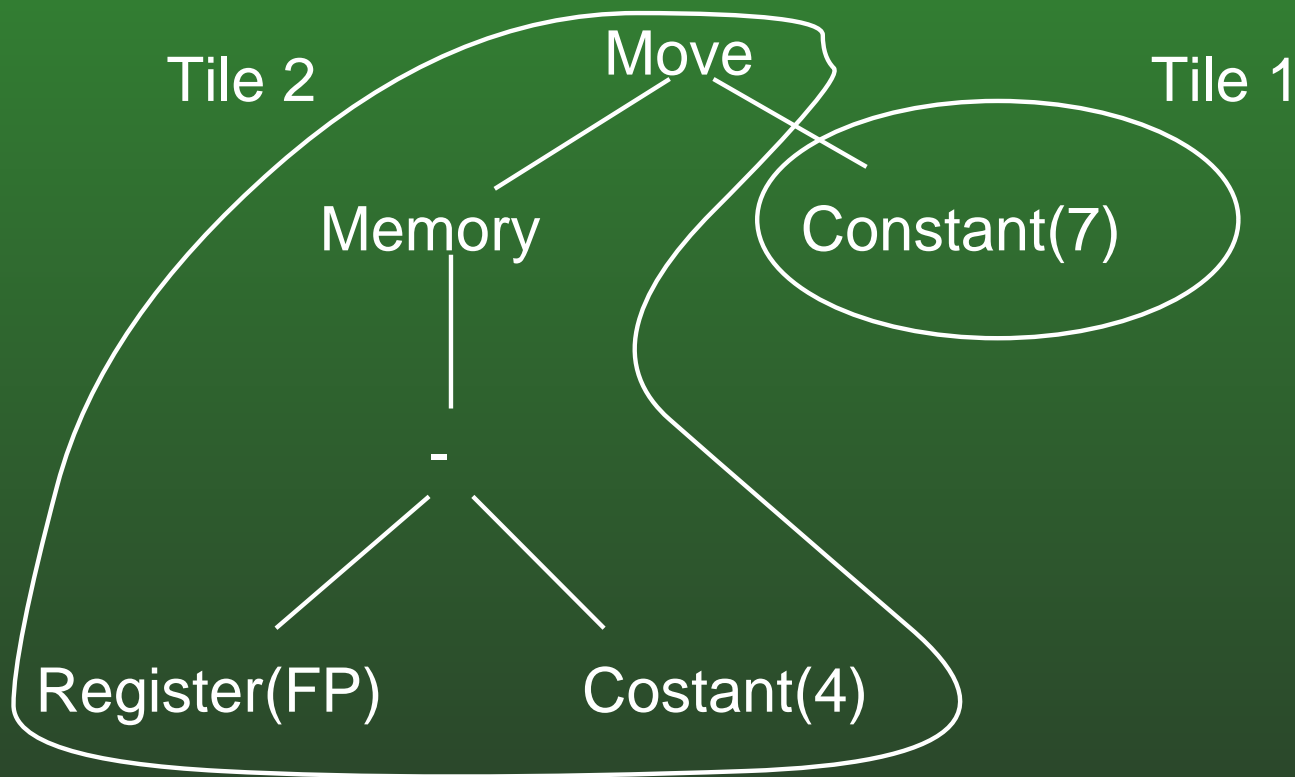

- Code for Tile 2?

```
sw $ACC, -4($FP)
```

FR-183: Larger Tiles Example

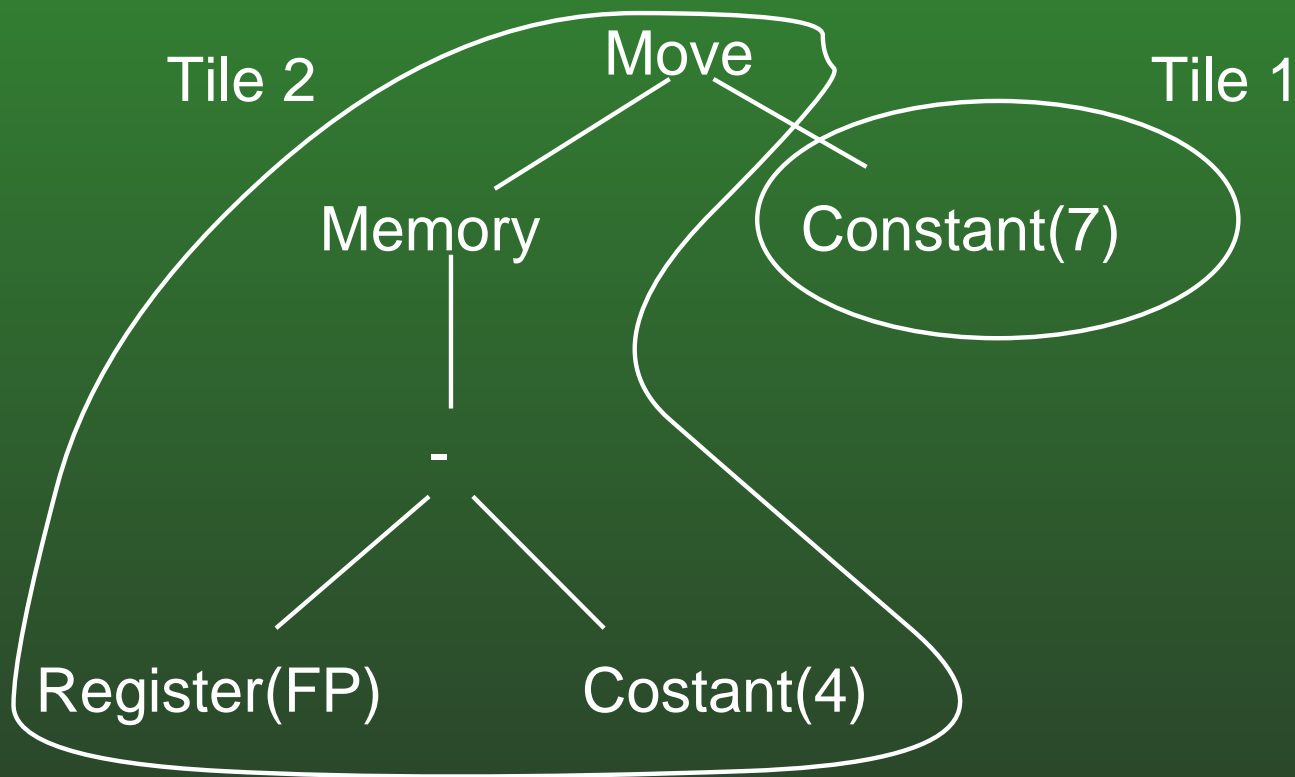

```
addi    $ACC, $zero 7    % tile 1
sw      $ACC, -4($FP)    % tile 2
```

FR-184: Adding New Instructions

- Added a new assembly language instruction:

```
loadmem $r1, <offset>($r2)
```

- $\text{MEMORY}[\$r1] = \text{MEMORY}[\$r2 + \text{offset}]$
- Create a tileset for this new instruction

FR-185: Adding New Instructions

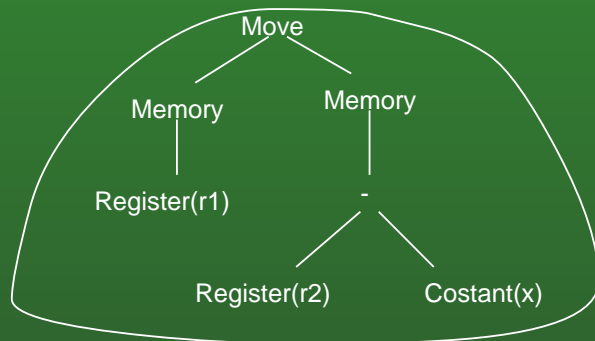

```
loadmem r1, -x(r2)
```

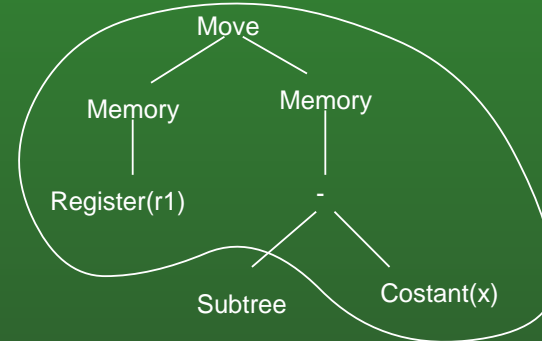

```
<code for Subtree>  
loadmem $r1, -x($ACC)
```

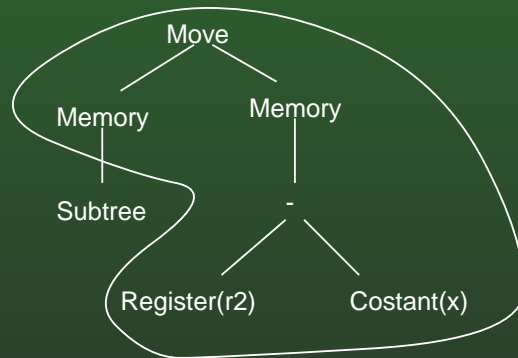

```
<code for Subtree>  
loadmem $ACC, -x($r2)
```

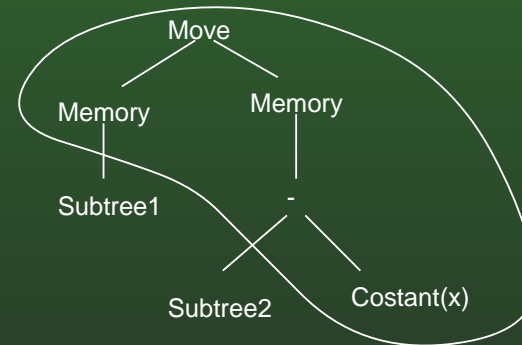

```
<code for Subtree1>  
sw  $acc, 0($ESP)  
addi $ESP, $ESP, -4  
<code for Subtree2>  
lw  $t1, 4($ESP)  
addi $ESP, $ESP, 4  
loadmem $t1, -x($ACC)
```

FR-186: Adding New Instructions

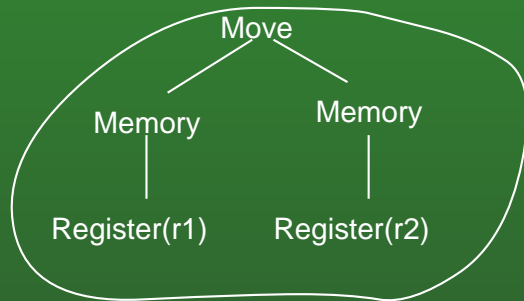

```
loadmem r1, 0($r2)
```

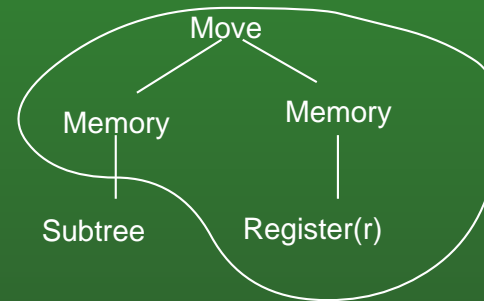

```
<code for Subtree>  
loadmem $ACC, 0($r)
```

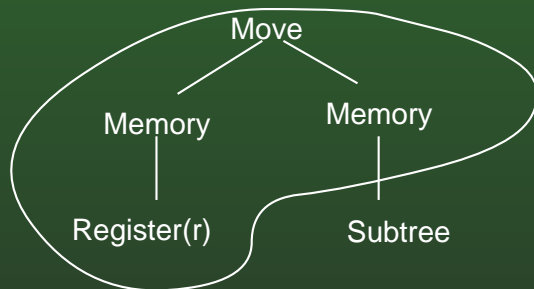

```
<code for Subtree>  
loadmem $r, 0($ACC)
```

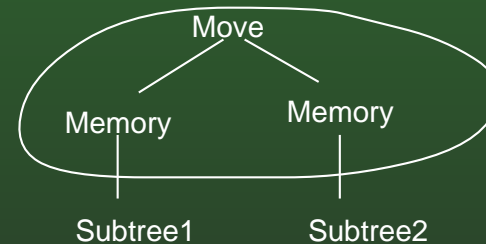

```
<code for Subtree1>  
sw    $ACC, 0($ESP)  
addi $ESP, $ESP, -4  
<code for Subtree2>  
lw    $t1, 4($ESP)  
addi $ESP, $ESP, 4  
loadmem $t1, 0($ACC)
```

FR-187: Adding New Instructions

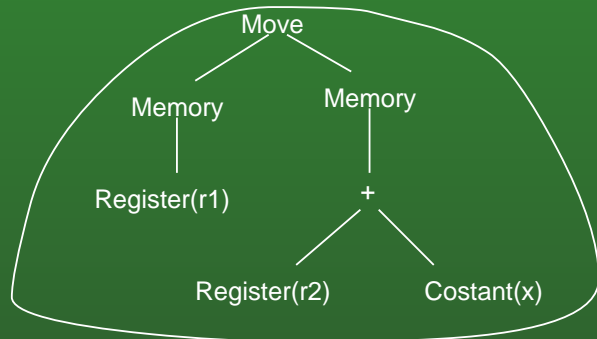

```
loadmem r1, x(r2)
```

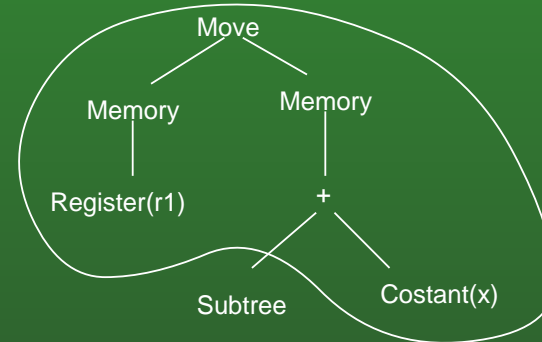

```
<code for Subtree>  
loadmem $r1, x($ACC)
```

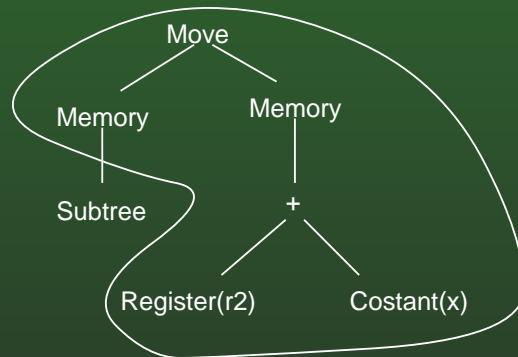

```
<code for Subtree>  
loadmem $ACC, x($r2)
```

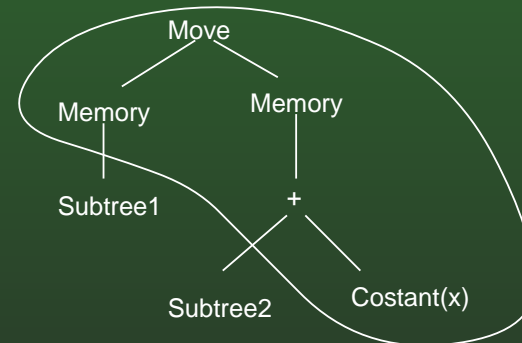

```
<code for Subtree1>  
sw  $ACC, 0($ESP)  
addi $ESP, $ESP, -4  
<code for Subtree2>  
lw  $t1, 4($ESP)  
addi $ESP, $ESP, 4  
loadmem $t1, x($ACC)
```

FR-188: Adding New Instructions

- Code that uses this tile:

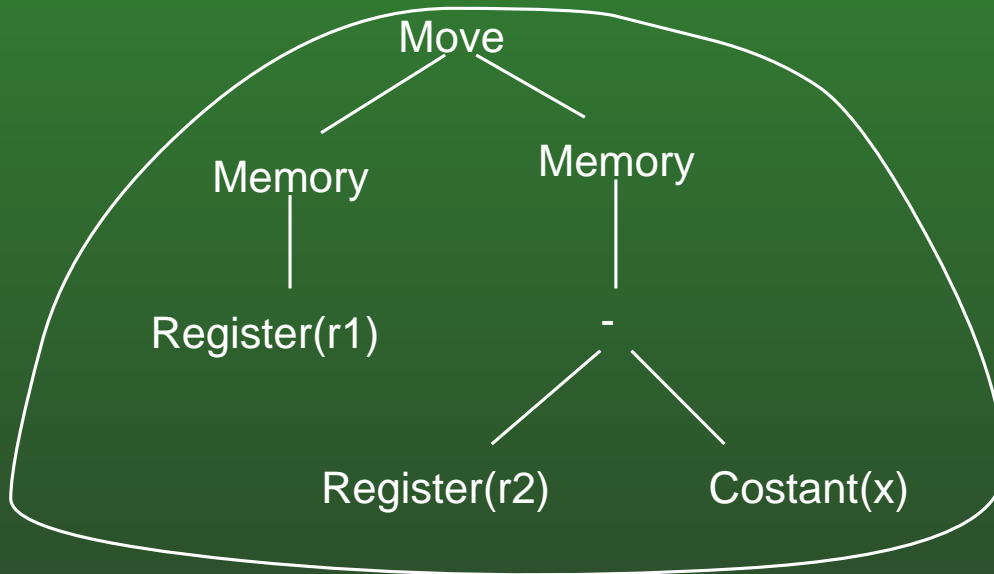

FR-189: Adding New Instructions

- Code that uses this tile:

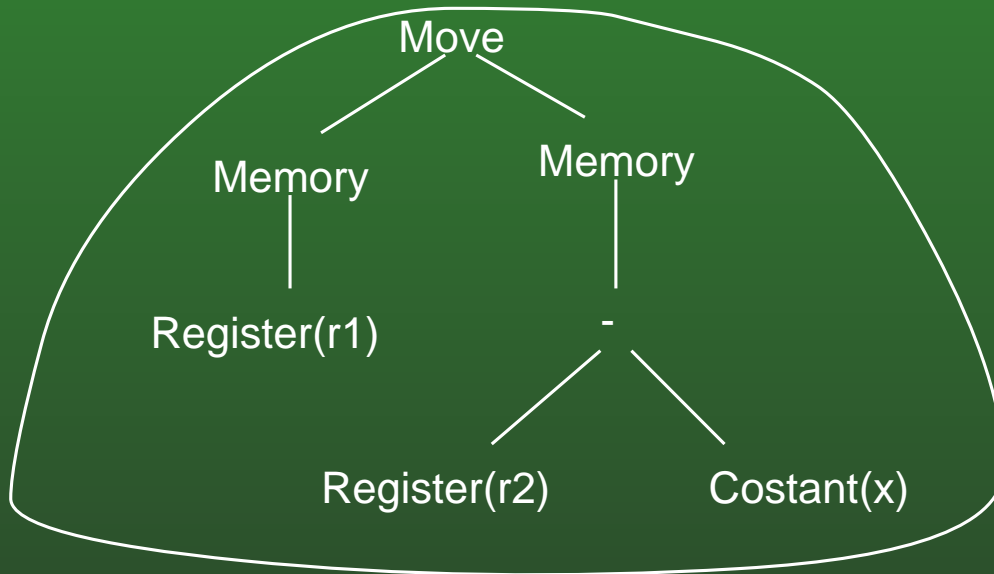

- $x = y;$
 - if x is at offset 0

FR-190: Adding New Instructions

- Code that uses this tile:

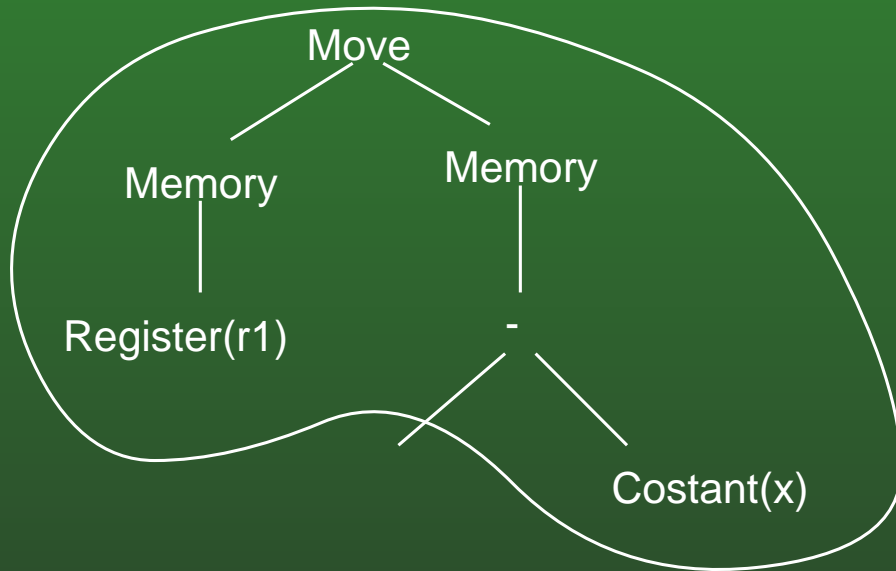

FR-191: Adding New Instructions

- simpleJava Code that uses this tile:

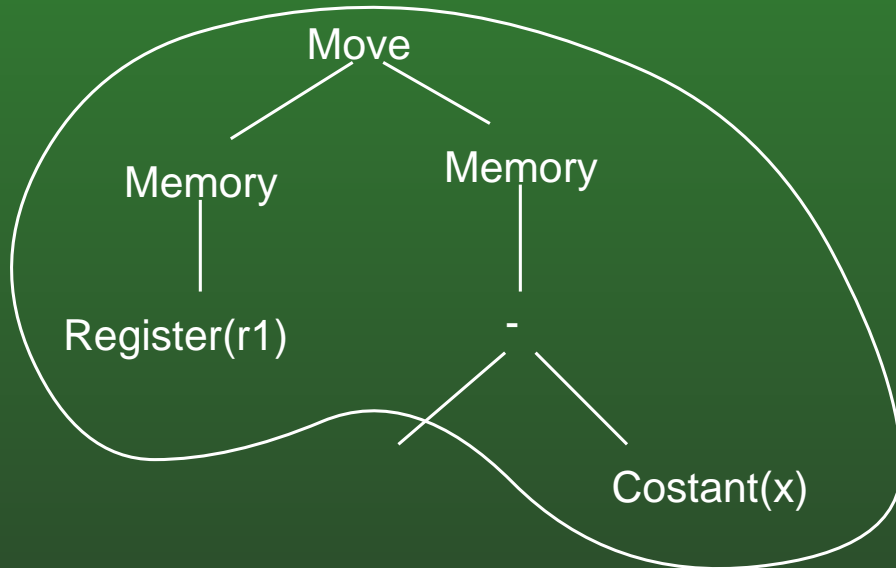

- $x = y.z;$
 - x is at offset 0

FR-192: Adding New Instructions

- $x = y.z;$
 - x is at offset 0, y is at offset 4, z is at offset 8

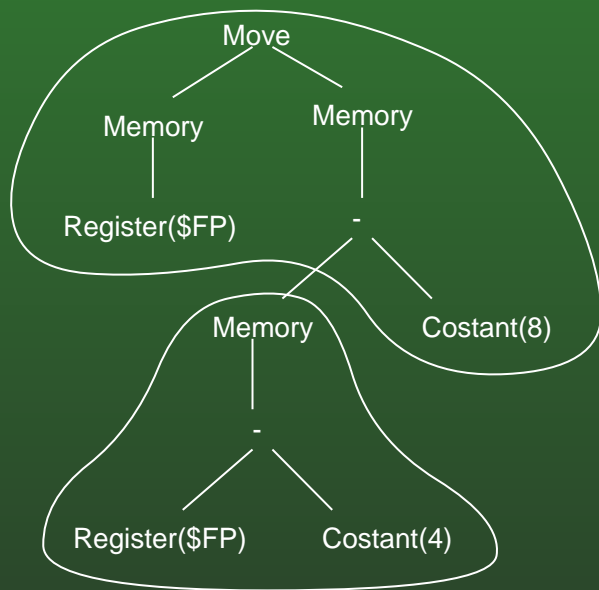

```
lw      $ACC, -8($FP)
loadmem $FP, -4($ACC)
```

FR-193: Questions on Final

You can expect to find the following types of questions on the final:

- Create a regular expression for a specific token type
 - Floating point numbers, different bases, etc
- Create a CFG for a language fragment
- Give the parse tree several strings for a given CFG
- Show that a CFG is ambiguous

FR-194: Questions on Final

You can expect to find the following types of questions on the final:

- Given a CFG G :
 - Remove left recursion
 - Left Factor
 - Find First/Follow sets for each non-terminal
 - Create a LL(1) Parse Table

FR-195: Questions on Final

You can expect to find the following types of questions on the final:

- Given a CFG G :
 - Create LR(0) states and transitions
 - Create LR(0) parse table
 - Find First/Follow sets for each non-terminal, create SLR(1) parse table

FR-196: Questions on Final

You can expect to find the following types of questions on the final:

- Given a new statement / expression type:
 - Create a new AST node (like Pascal For loops)
 - Given a piece of simpleJava code, give the AST that represents that piece of code

FR-197: Questions on Final

You can expect to find the following types of questions on the final:

- Given a piece of simpleJava code
 - Give the AAT that represents that piece of code
 - Tile the AAT, by drawing a circle around each tile. Each tile should be implemented by a single assembly language instruction, plus any extra instructions that are necessary for stack maintenance.
 - Show the generated code, noting which tile each line of assembly came from

FR-198: Questions on Final

You can expect to find the following types of questions on the final:

- Given a new assembly language instruction:
 - Create a tileset for that assembly language instruction, showing which code is associated with each tile
 - Give simpleJava code that uses one (or more) of these tiles
 - Show the assembly tree for the simpleJava code, circle tiles, and show final assembly language

FR-199: Questions on Final

You can expect to find the following types of questions on the final:

- Thinking / Synthesis question
 - Use information in slightly new ways
 - A little beyond “turn the crank”